

A Compact Energy-Efficient Wireless Recorder for the Acquisition of Neural Signals

**Rodney J. Chandler¹
and Jack W. Judy^{1,2}**

¹Electrical Engineering Department

²Biomedical Engineering IDP

University of California, Los Angeles

UCLA
judylab.org



Outline

- **Motivation**
- **Existing System Implementations**
- **Proposed System Architecture**
- **Performance Comparison**
- **Conclusions**

Outline

- **Motivation**
 - **Basic Research**
 - **Disease Research**
 - **Brain-Computer Interfaces**
- **Existing System Implementations**
- **Proposed System Architecture**
- **Performance Comparison**
- **Conclusions**

Motivation

- **Basic Research**
 - Neuroscience
- **Disease Research**
- **Brain-Computer Interfaces (BCI)**

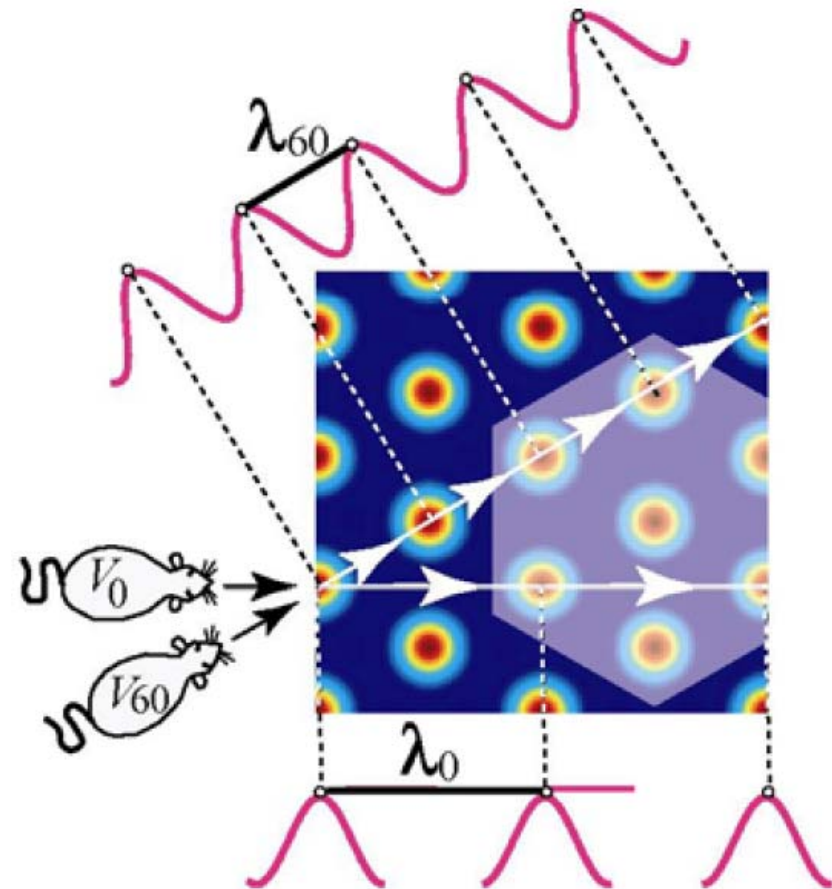
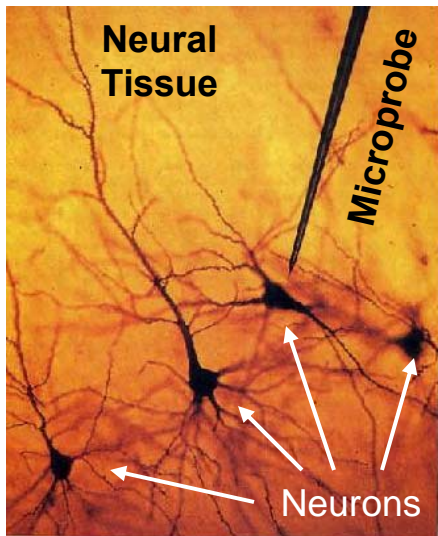

- **Grid Cells**
 - firing rate varies with position
 - spatial grid

Motivation

- Basic Research
- Disease Research
 - many channels
 - signal processing
 - application: Epilepsy
- Brain-Computer Interfaces (BCI)

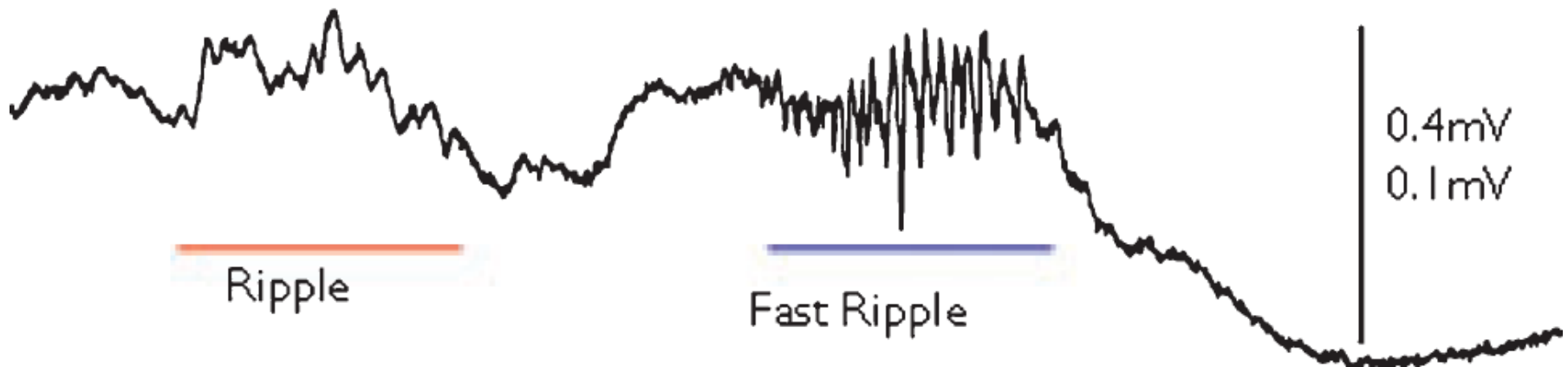
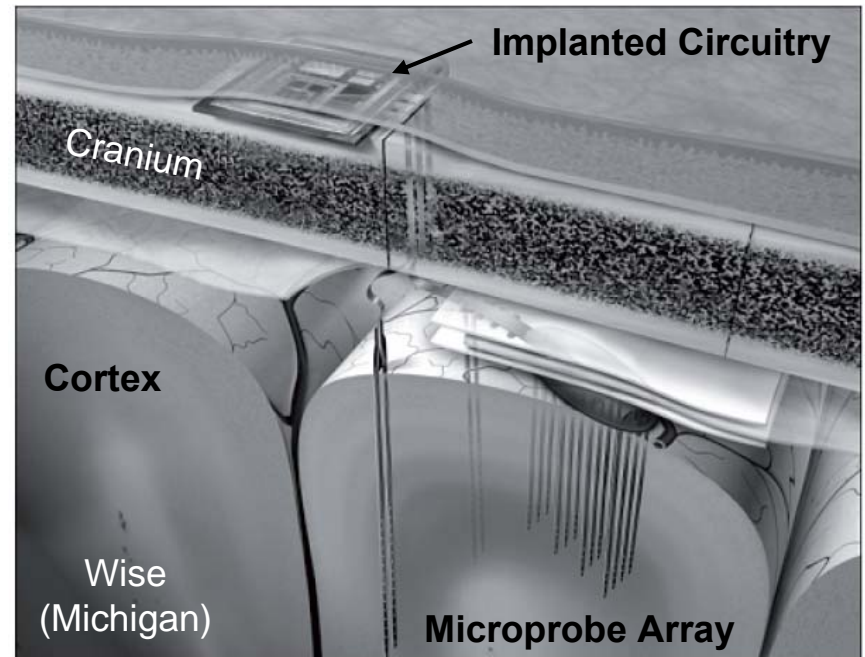

Motivation

- Basic Research
- Disease Research
- **Brain-Computer Interfaces (BCI)**
 - control prosthetic limbs
 - enable non-verbal communication



Example: Experimental Setup

Head-Mounted Electrodes

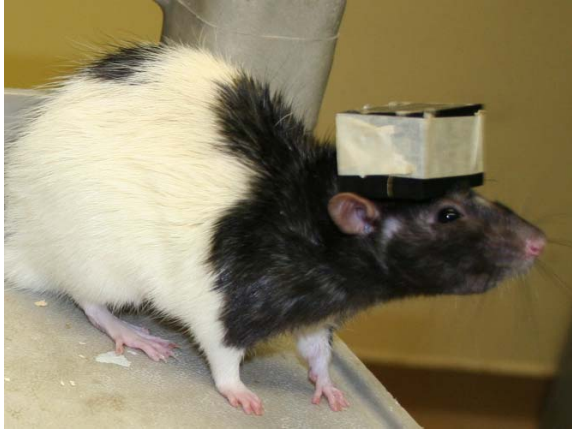

Preamplifier with Headstage

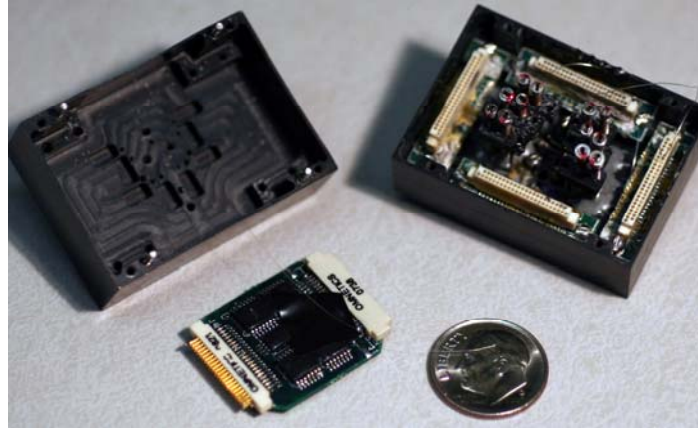

Cables/Commutator



Preamplifier Board

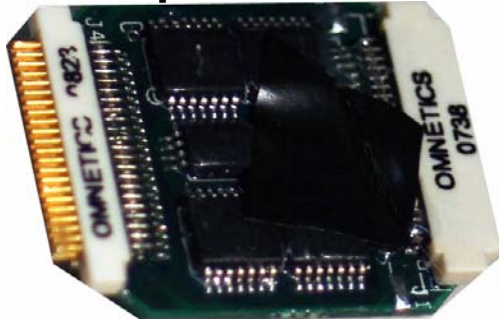

Interface Detail

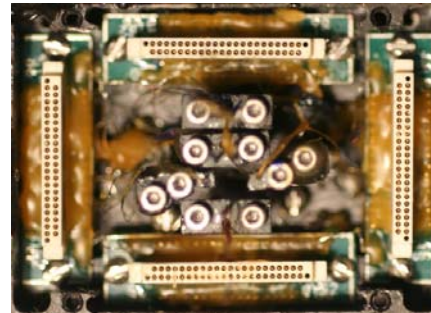

- Clear need for a low-power, compact, wireless solution

Outline

- Motivation
- **Existing System Implementations**
 - Neural Signals
 - Analog Processing
 - Spike Detection
 - Spike Sorting
- Proposed System Architecture
- Performance Comparison
- Conclusions

Classes of Biosignals

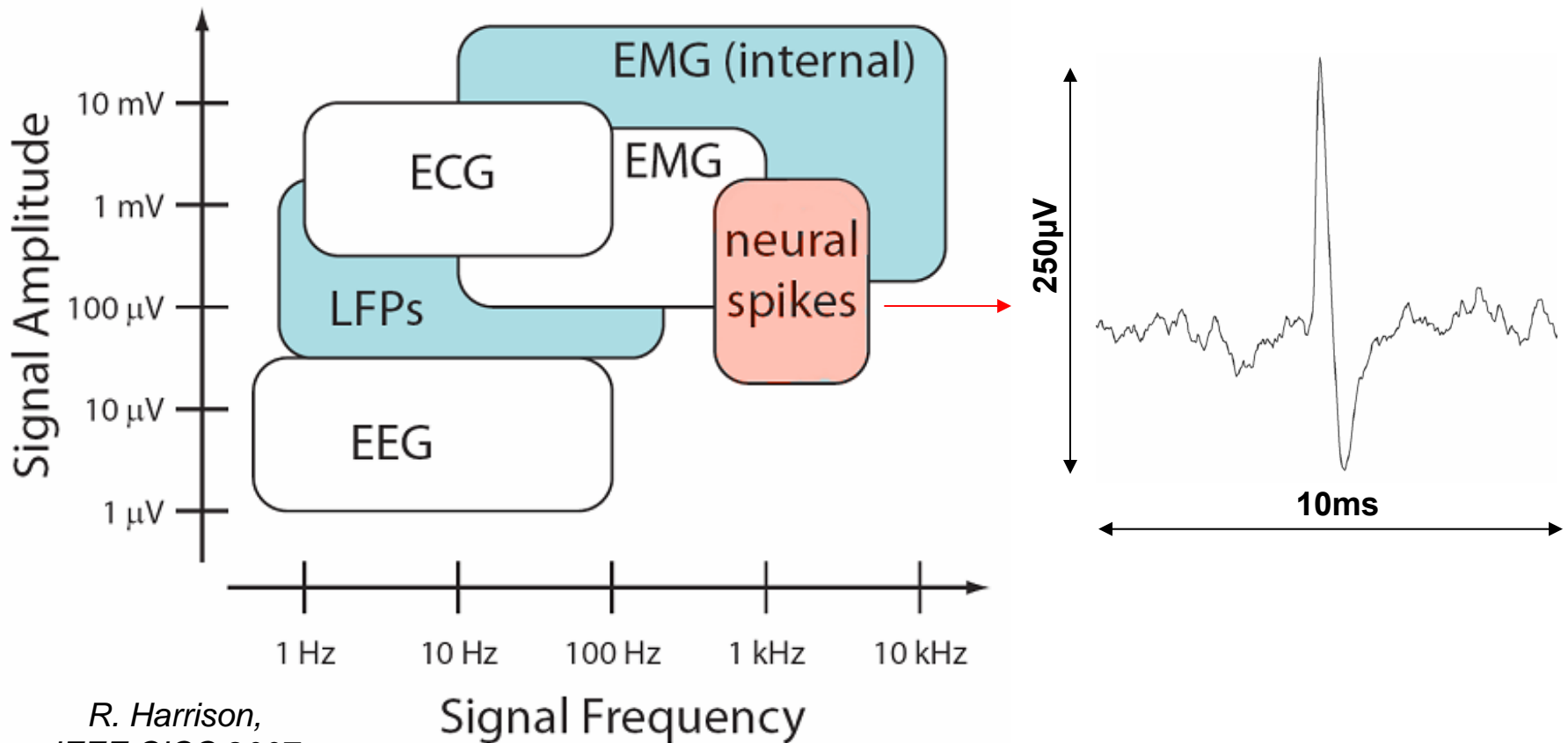

- **Signal of Interest: *Neural Spikes***
 - wave-shape characteristics used to detect and classify

Neurons

- **Action Potential**
 - due to current flow of ions through membrane
- **Modeled as voltage source**

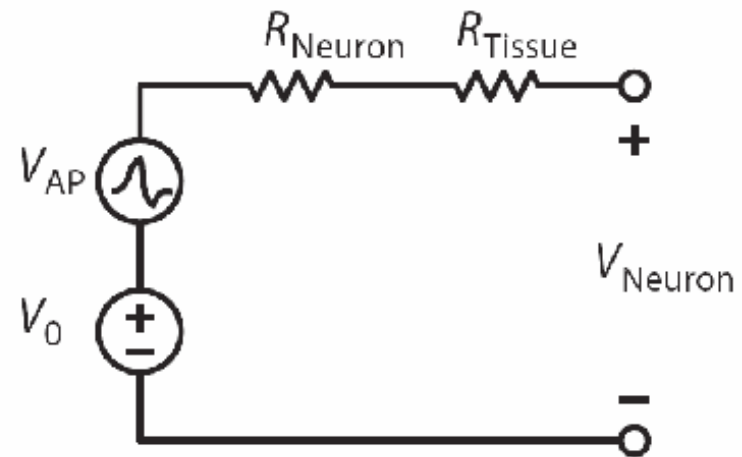
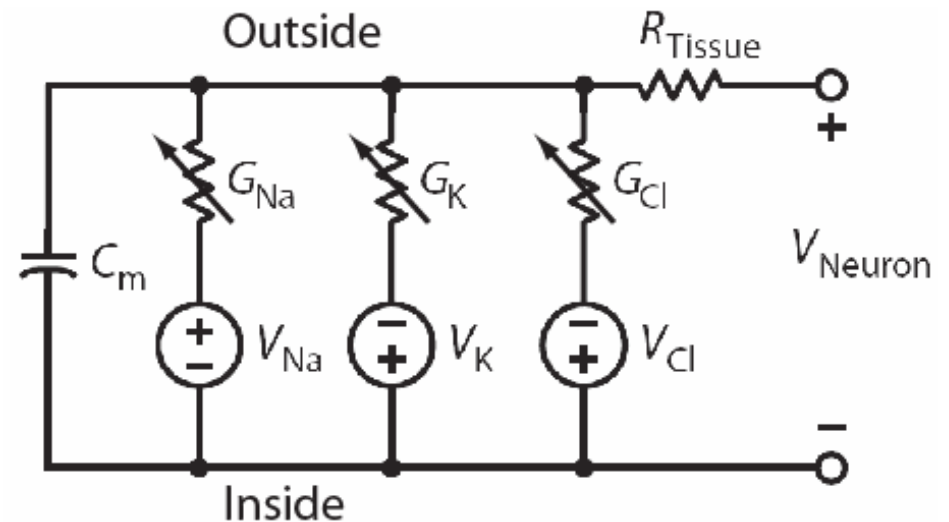
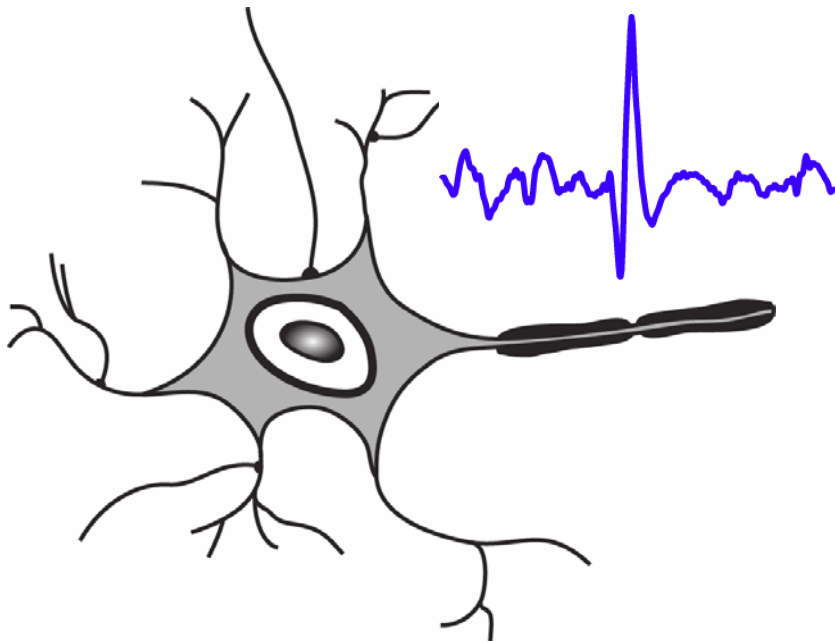

Recorded Waveforms

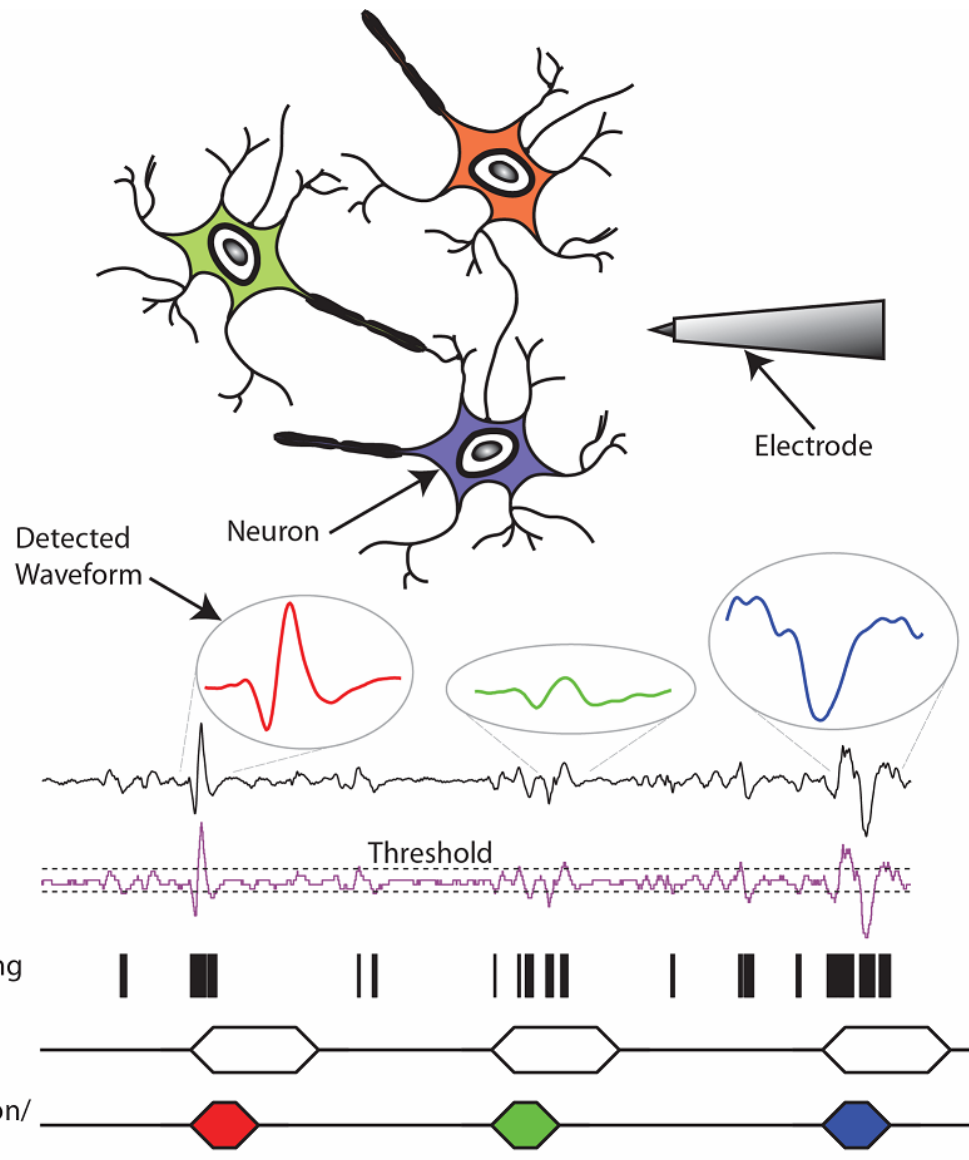

- **Infrequent Activity**
- **Background Noise**
- **Approaches:**
 - **Raw Streaming**
 - **Spike Detection**
 - **Sorting**

Existing Implementations: *Raw Streaming*

- **Analog telemetry**
- **Low-channel count**

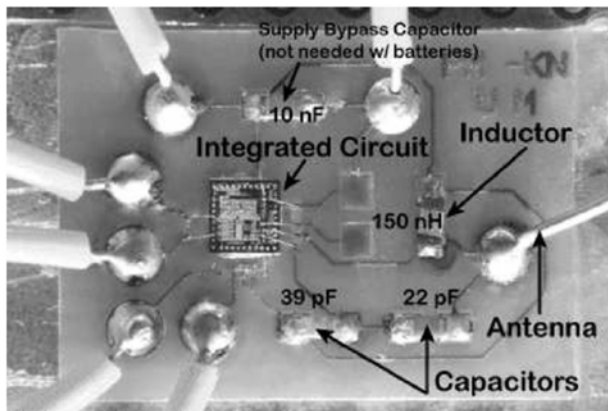

Mohseni 2005

4 channels
2.2 mW
1.1 g



TBSI 2008

31 channels
30 mW
7.2 g

**Only
Commercial
Product
Available**

**Core IC
Technology
Developed
at UCLA by
our Group:
Irazoqui
2003**

Existing Implementations: *Spike Detection (Simple Threshold Only)*

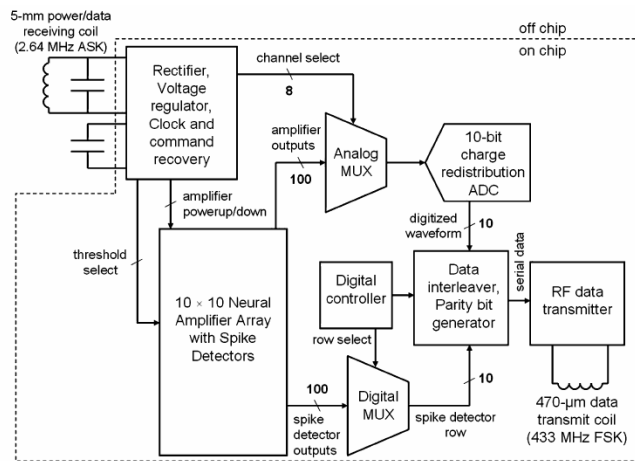

Harrison 2007

100 channels

13.8 mW

on-chip spike detection

1 channel digitized

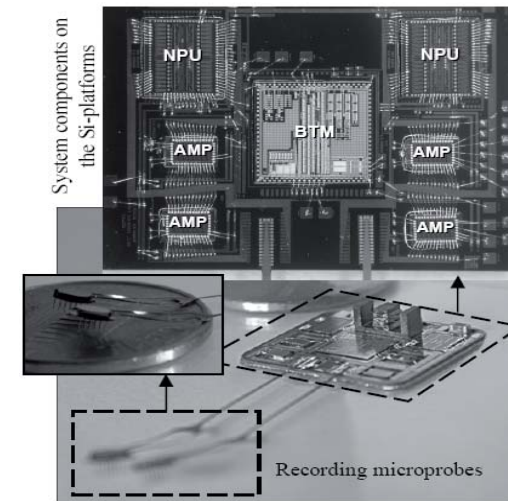

Sodagar 2007

64 channels

14.4 mW

0.3 g

scan & monitor

- **Information Transmitted:** *spike time and channel only*

Existing Implementations: *Spike Detection and Sorting*

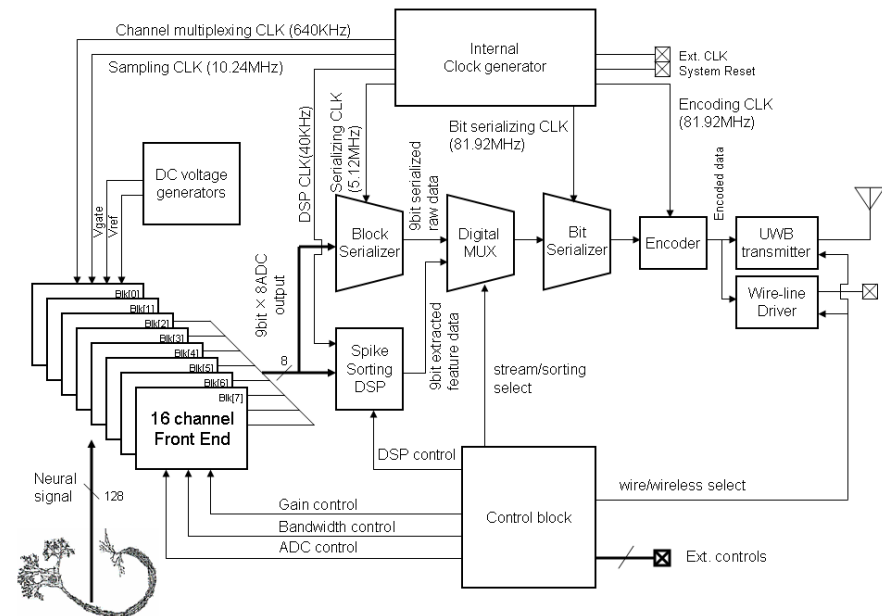
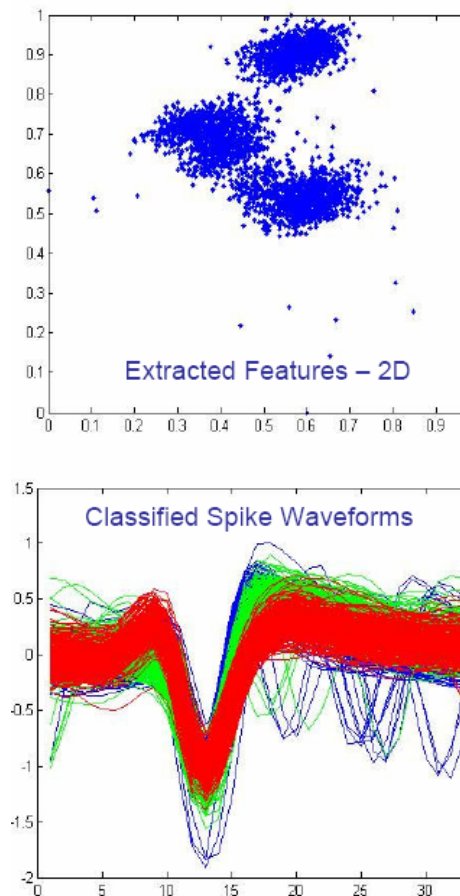

Chae 2008

128 channels

6.0 mW

spike-sorting DSP

- **Information Transmitted:** *spike time, channel, and cell*

Existing Implementations: *Summary*

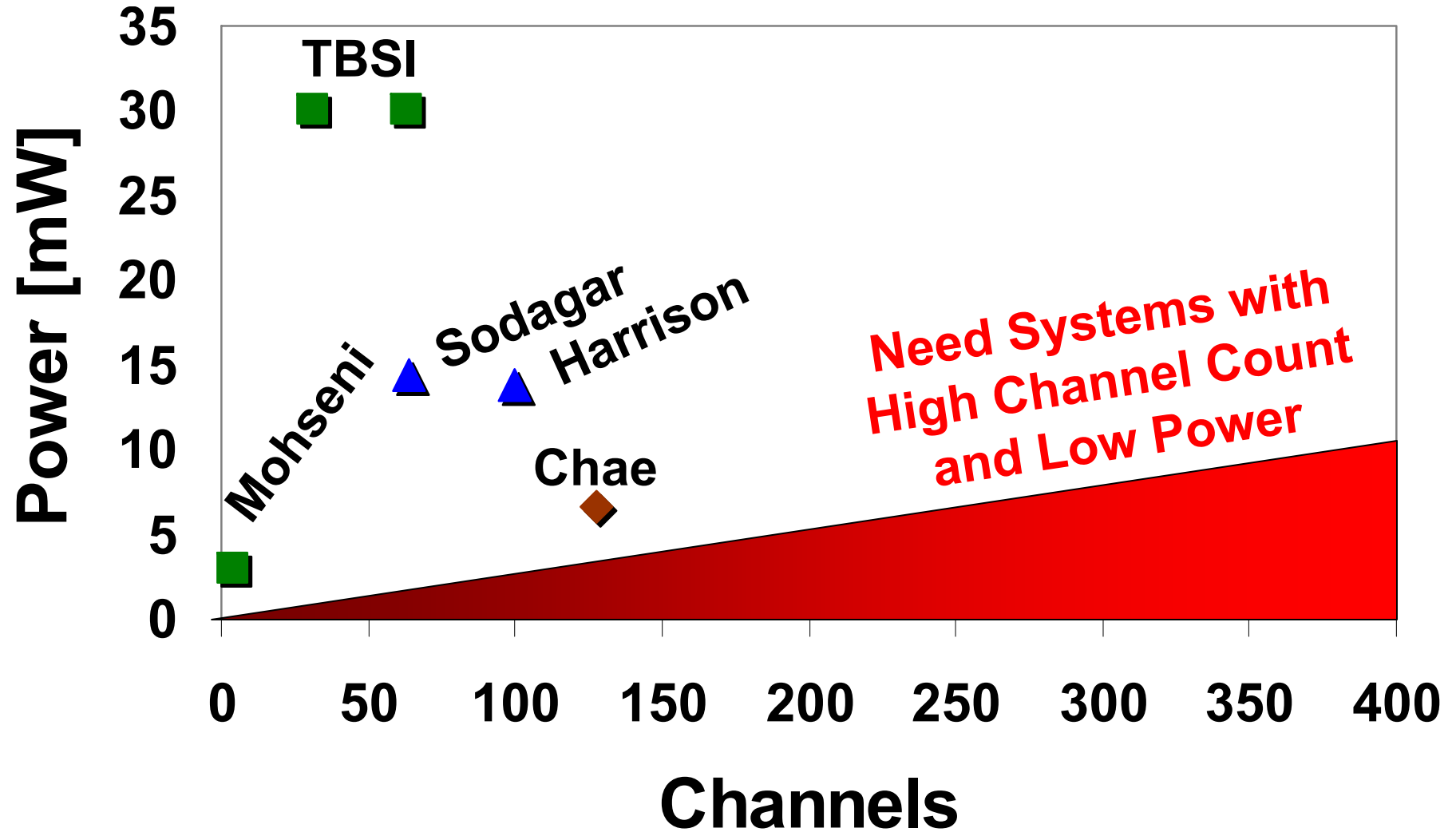

Outline

- Motivation
- Existing System Implementations
- **Proposed System Architecture**
 - Capturing Neural Signals
 - Micro-Power Amplifiers
 - Analog-to-Digital Converters
 - Spike Detection
 - Telemetry Considerations
- Performance Comparison
- Conclusions

Goals of the Project

- **Low Noise**
 - 3 μV input referred
- **Low Power**
 - $< 80 \mu\text{W}$ / channel
- **Small Area for High Integration**
 - 100 channels in 10 mm^2
- **On-Chip Signal Processing**
- **Wireless Communication**
 - Range: $> 10 \text{ m}$
 - Throughput: up to 10 Mbps

Block Diagram

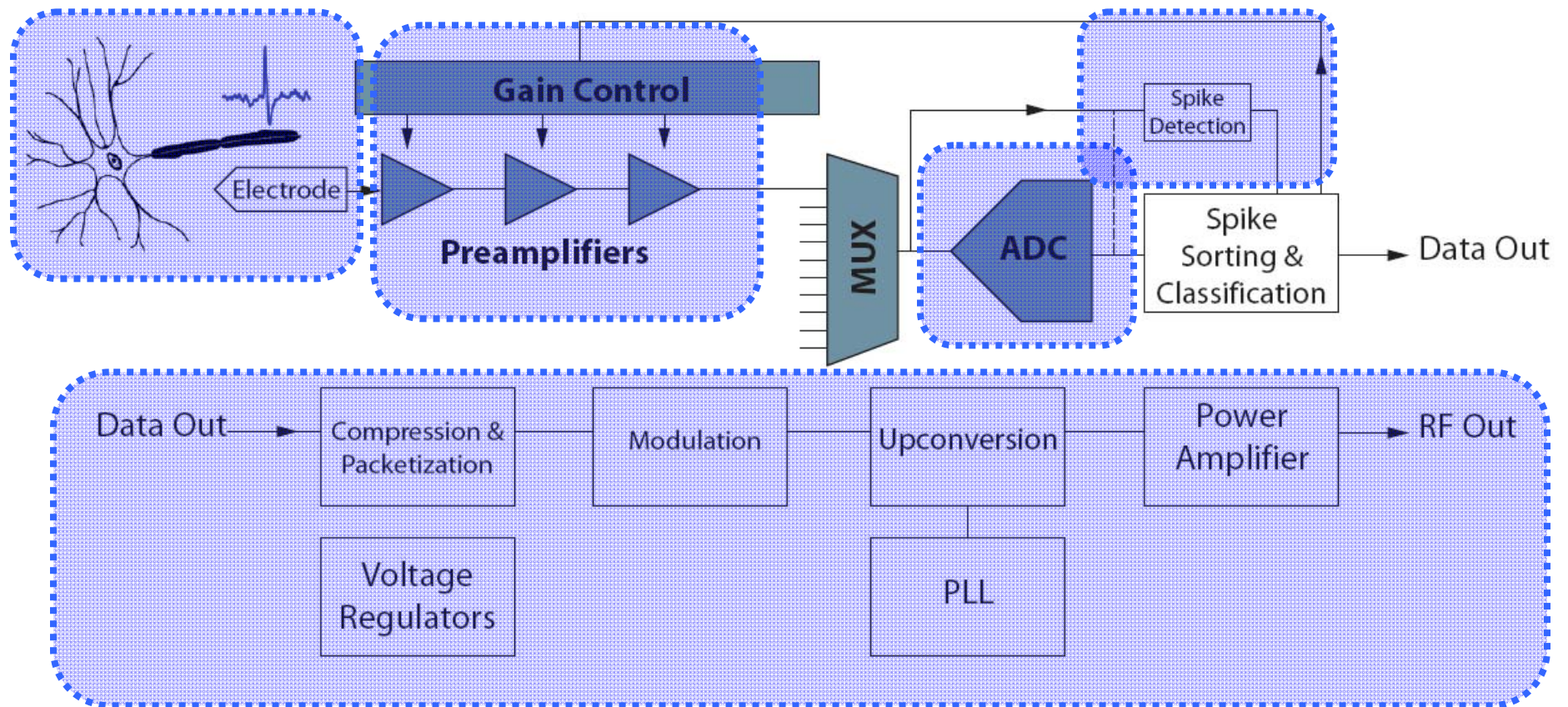

Outline

- Motivation
- Existing System Implementations
- Proposed System Architecture
 - **Micro-Power Amplifiers**
 - Block-level design
 - Power, Area, and Noise Tradeoffs
 - Circuit Design & Proposed Amplifier
 - Analog-to-Digital Converters
 - Spike Detection
 - Telemetry Considerations
- Performance Comparison
- Conclusions

Micro-Power Amplifiers

- **AC-Coupled Amplifier**
 - Removes dc-offset

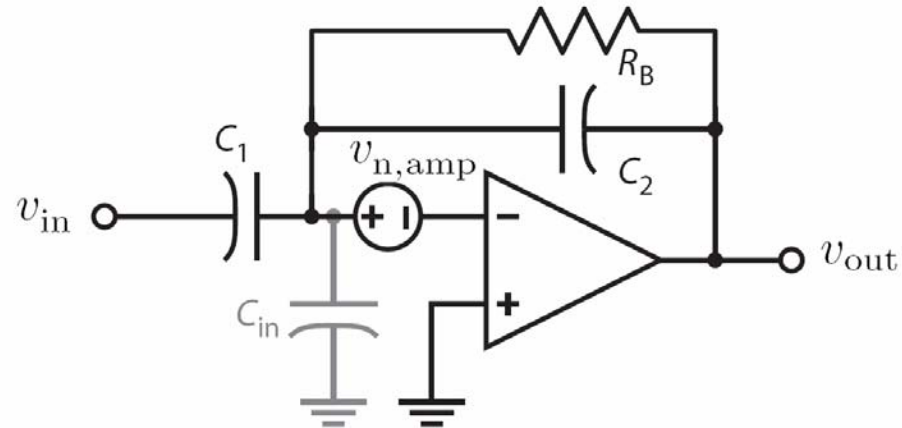

$$\text{Amplifier: } v_{\text{in}}^2 = \left(\frac{C_1 + C_2 + C_{\text{in}}}{C_1} \right)^2 \cdot v_{\text{n,amp}}^2$$

$$\text{Resistor: } v_{\text{in}}^2 = \frac{2}{\pi} \frac{1}{A_V f_L} \cdot \frac{kT}{C_1} \cdot \frac{1}{f^2}$$

- **Design Trade-Off:**
 - Maximize C_1 to minimize noise
 - Minimize C_1 to minimize area

Minimum Thermal Noise

$$v_{\text{in}}^2 = \left(\frac{C_1 + C_2 + C_{\text{in}}}{C_1} \right)^2 \cdot v_{\text{n,amp}}^2$$

$$v_{\text{n,amp}} \propto 1/I_D$$

$$C_{\text{in}} \propto I_D$$

$$\min(v_{\text{in}}^2) = 8 \cdot \frac{1 + C_2/C_1}{C_1} \times \frac{\gamma \cdot K_{\text{AMP}} \cdot q \cdot L^2}{\mu} \cdot \left(1 + \frac{1 - \kappa}{IC} \right)$$

- **Minimum noise occurs when $C_{\text{in}} = C_1 + C_2$**

Thermal Noise vs. Area

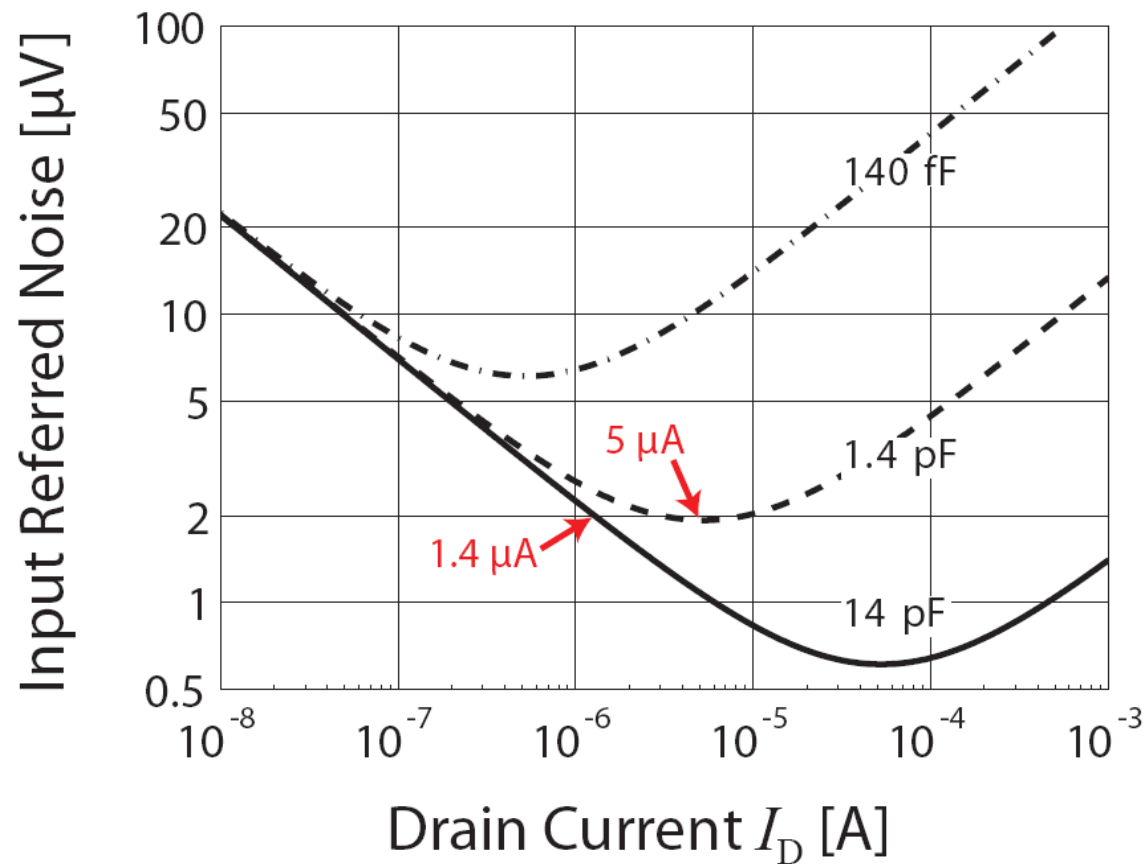

- **Must choose C_1 carefully**
 - trade-off area, power, and noise

Flicker-Noise Contribution

Noise Contours [μV]
 $BW = 10 \text{ kHz}$, $KF = 2.36 \times 10^{-25}$, $C_{\text{ox}} = 15.7 \text{ fF}/\mu\text{m}^2$

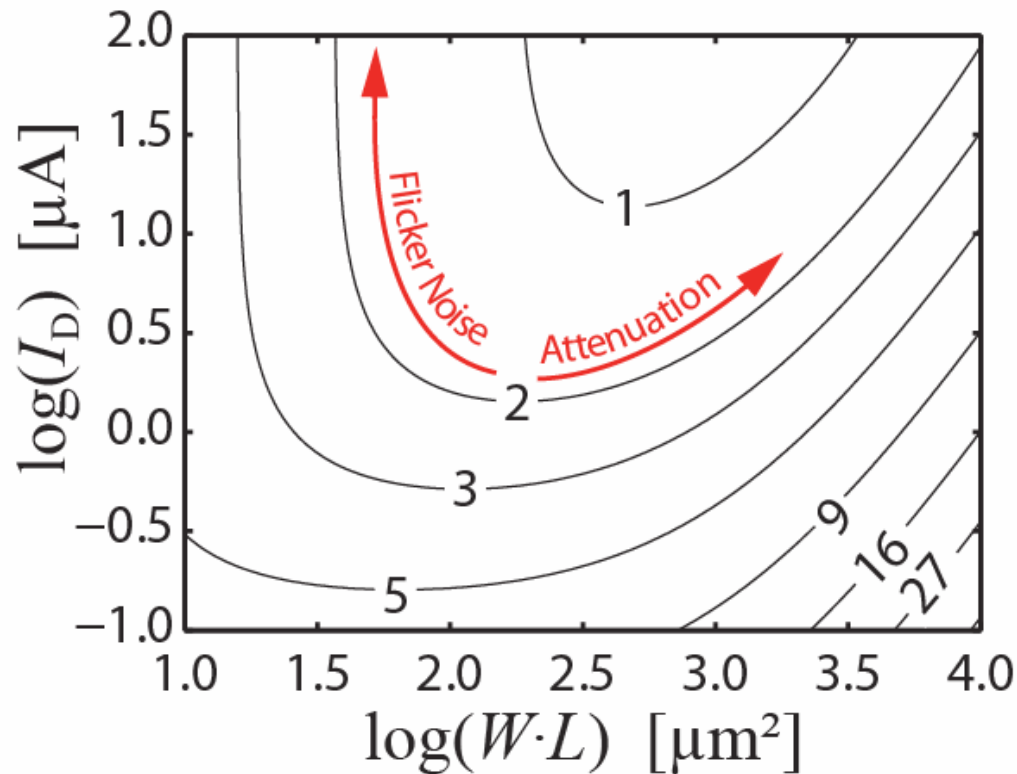

- **For 2 μV noise:**

$$I_D = 1.4 \mu\text{A}$$

$$WL = 177 \mu\text{m}^2$$

**Flicker-Noise
Contribution:**

$$v_{\text{in}}^2 = \left(\frac{C_1 + C_{\text{eff}} \cdot W \cdot L}{C_1} \right)^2 \cdot \frac{KF}{C_{\text{eff}} \cdot W \cdot L} \cdot \frac{1}{f}$$

Circuit Choices

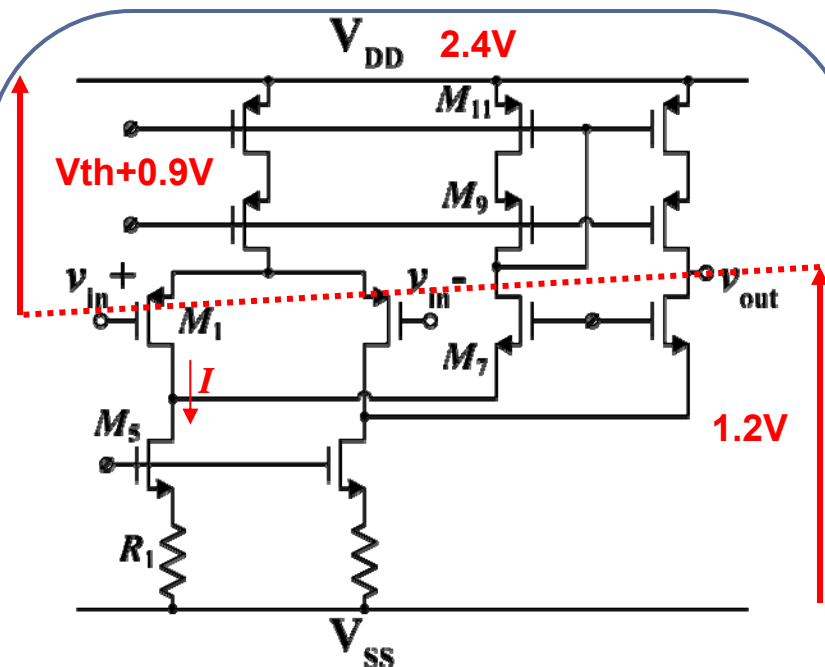

- $V_{DD} > V_{th} + 2.1 \text{ V}$
for low noise
- Current-scaled FCOTA with degeneration
- Gain set by C_1/C_2

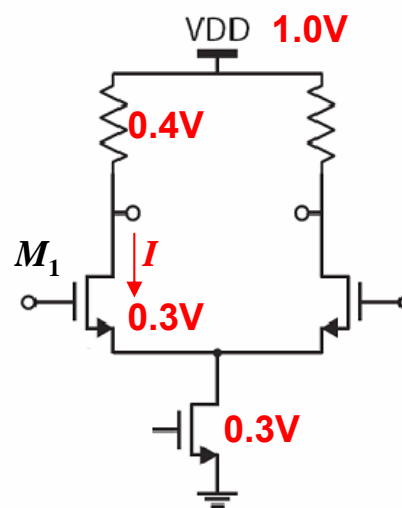

- $V_{DD} > n \cdot A_V \cdot V_T + 0.6 \text{ V}$
- Low gain per stage
- Gain varies with process and temperature
- Requires calibration

W. Wattanapanitch, IEEE Trans on Biomedical Circuits and Systems

Cascaded Amplifiers

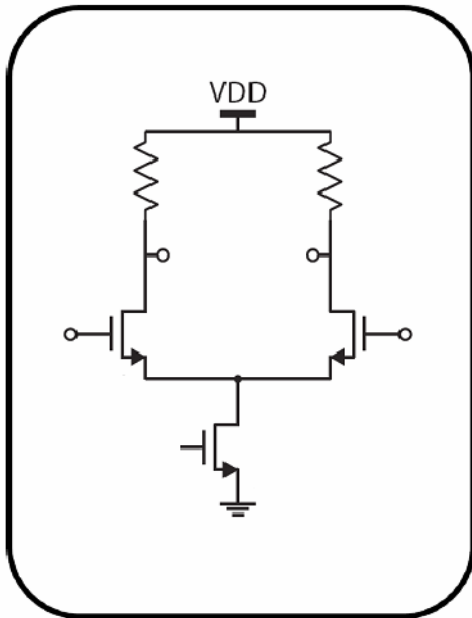

$$v_{\text{in,stage}}^2 = \frac{8 \cdot k \cdot T \cdot \gamma}{g_{m1}} \cdot \left(1 + \frac{1}{A_V}\right)$$
$$v_{\text{in,total}}^2 = v_{\text{in,stage}}^2 \cdot \left(\frac{1}{1 - 1/A_V^2}\right)$$
$$\approx 1.1 \times v_{\text{in,stage}}^2$$

$$A_V = g_{m1} \cdot R_L \approx 10$$

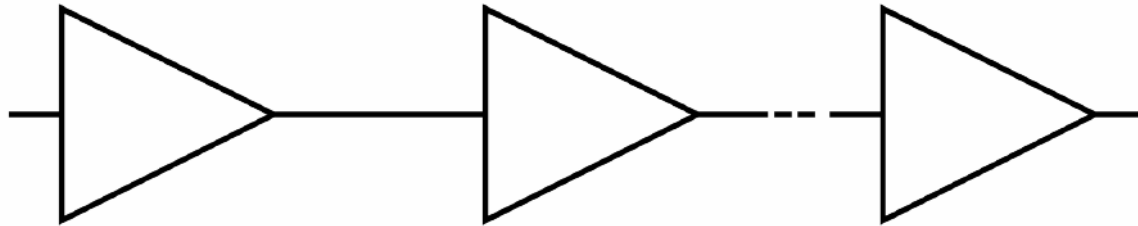

- **Noise set by achievable gain**
- **First stage dominates noise performance**

Amplifier Comparison

Author	Noise (μV)	Area (mm^2)	Power (μW)	BW (kHz)	VDD (V)	NEF	NP (μW)
Perelman	3	NR	1000	10	3.3	19.33	1000
Denison	9.4	NR	1.8	0.25	1.8	22.00	706
Olsson	9.2	0.177	68	10	3	16.21	639
Aziz	13	0.052	23	10	3.3	12.70	431
Borghetti	2.9	0.14	248	20	3.3	6.58	116
Harrison	2	0.16	80	10	5	2.96	36
Chae	4.9	0.4	23	20	3.3	3.39	31
Gosselin	5.6	0.05	8.6	10	1.8	4.53	30
Wattanapanitch	3.1	0.16	7.6	5.3	2.8	2.60	15
This Work	3	0.1	6.2	10	1	2.76	6

Normalized Power:

$$NP = Power \cdot \left(\frac{3 \mu\text{V}}{Noise} \right)^2 \cdot \frac{BW}{10 \text{ kHz}}$$

- **Our Design:**
 - **2.5x better (lower power)**

Outline

- Motivation
- Existing System Implementations
- Proposed System Architecture
 - Capturing Neural Signals
 - Micro-Power Amplifiers
 - **Analog-to-Digital Converters**
 - ADC Requirements
 - State-of-Art ADCs
 - Spike Detection
 - Telemetry Considerations
- Performance Comparison
- Conclusions

Analog-to-Digital Converter

- **Low Power**
 - $< 20 \mu\text{W}$ per channel
 - 66 pJ per conversion
- **Low Area**
 - $< 0.01 \text{ mm}^2$ per channel
- **Easy to Multiplex many channels**
 - reduces area required
- **Resolution:**
 - 8 to 12 bits

SAR ADC is a good choice

ADC Comparisons

- **Specs: 2-mW, 3-MS/s, 12-bit ADC (achievable)**

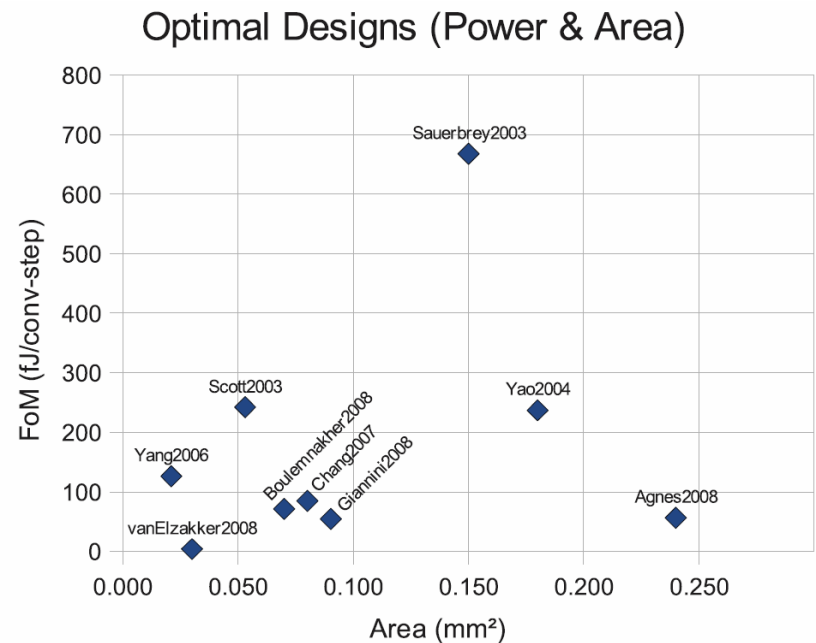
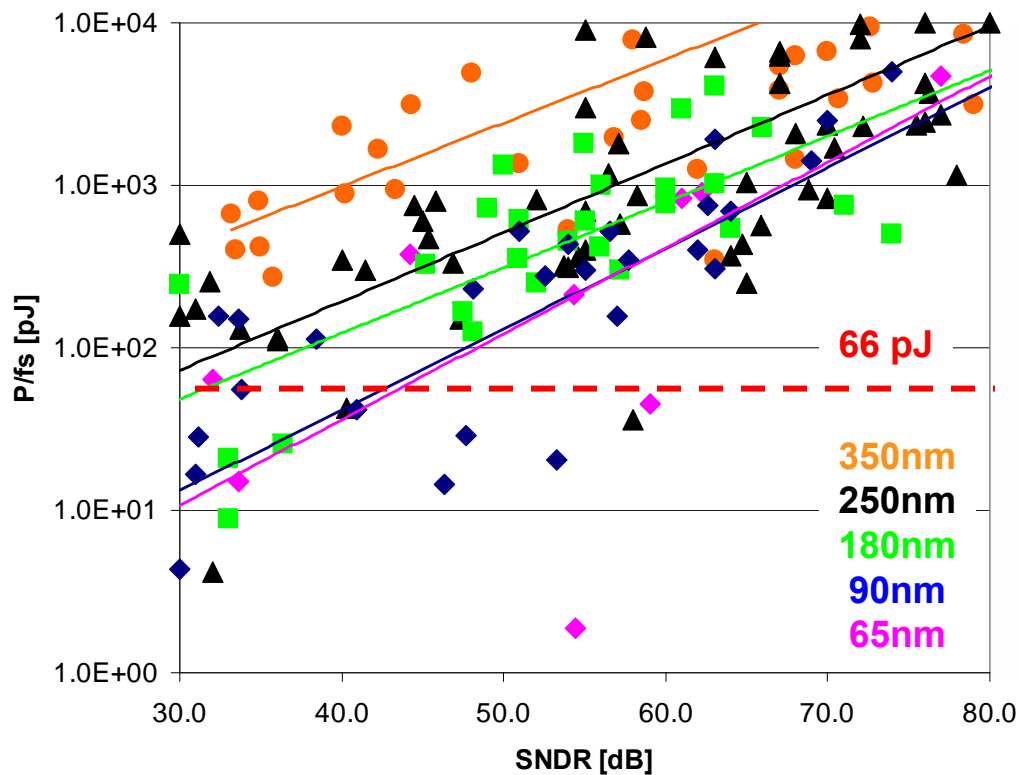

B. Murmann, "ADC Performance Survey 1997-2008," [Online].
<http://www.stanford.edu/~murmman/adcsurvey.html>.

Outline

- Motivation
- Existing System Implementations
- Proposed System Architecture
 - Capturing Neural Signals
 - Micro-Power Amplifiers
 - Analog-to-Digital Converters
 - **Spike Detection**
 - Telemetry Considerations
- Performance Comparison
- Conclusions

Analog Spike Detection

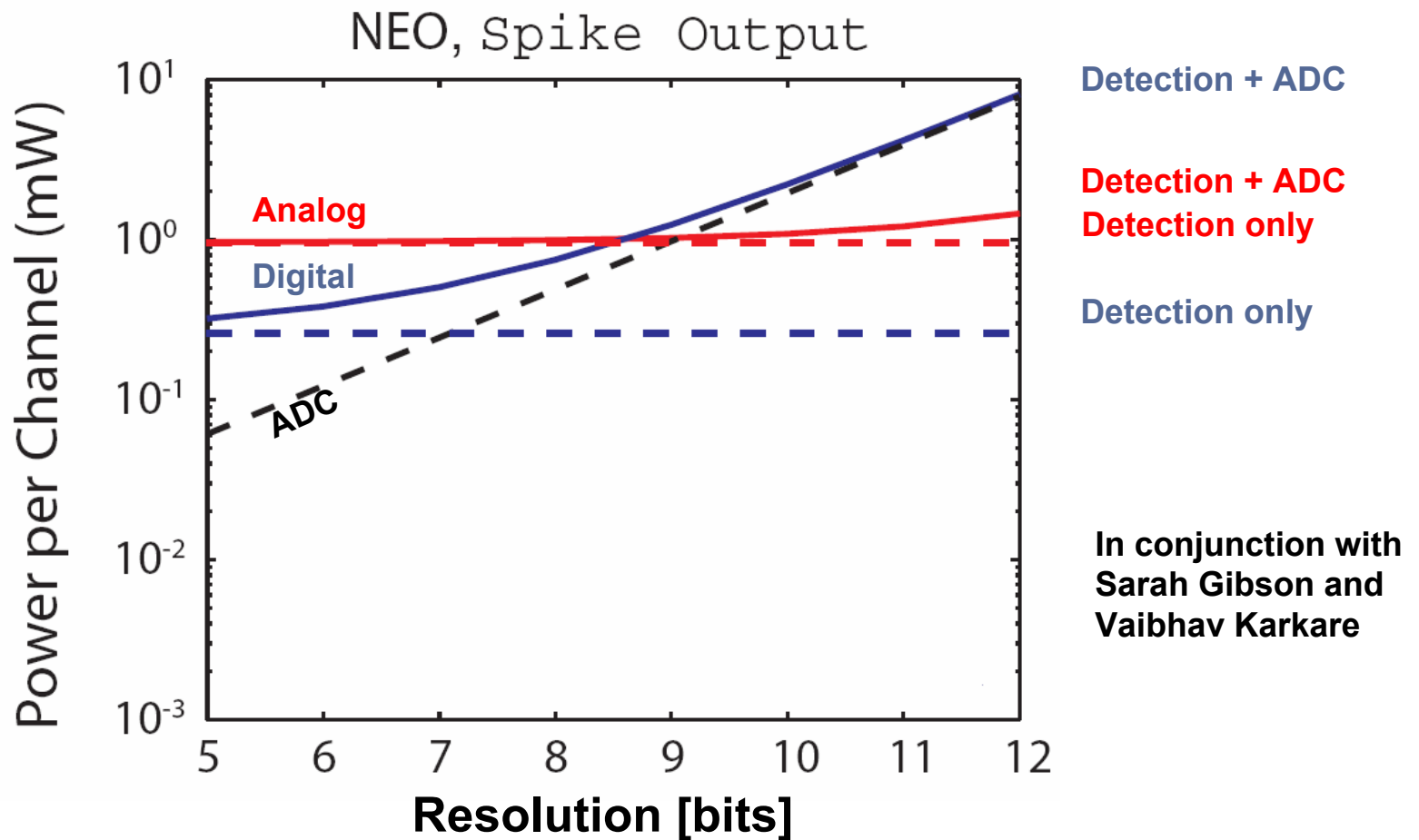

- **Analog Detection preferable at high resolution: > 8 bit**

Analog NEO Detector

- **Analog Spike-Detection Circuitry**
 - Implementation of Non-Linear Energy Operation Detector

$$\psi[x(n)] = x^2(n) - x(n+1) \cdot x(n-1)$$

- **More reliable than simple threshold in low SNR**

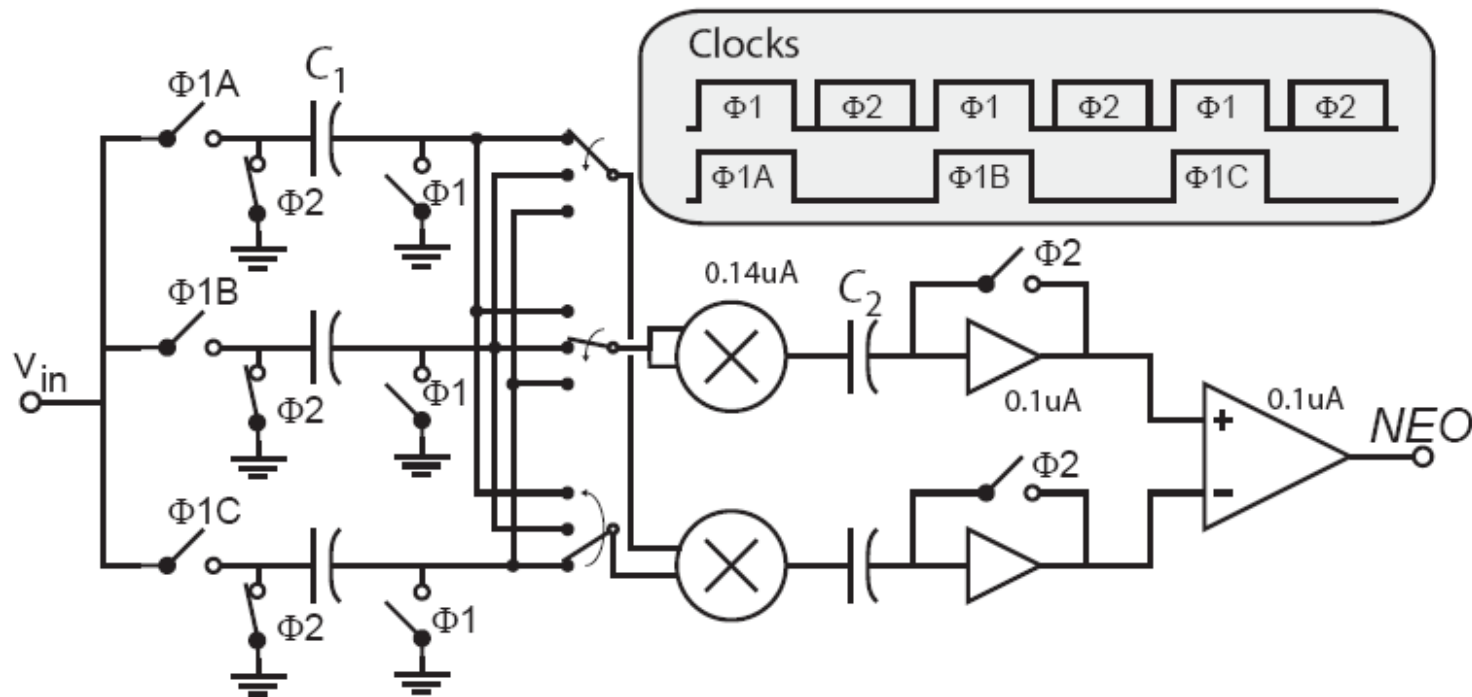

Outline

- Motivation
- Existing System Implementations
- Proposed System Architecture
- **Performance Comparison**
- Conclusions

Comparison to Existing Work

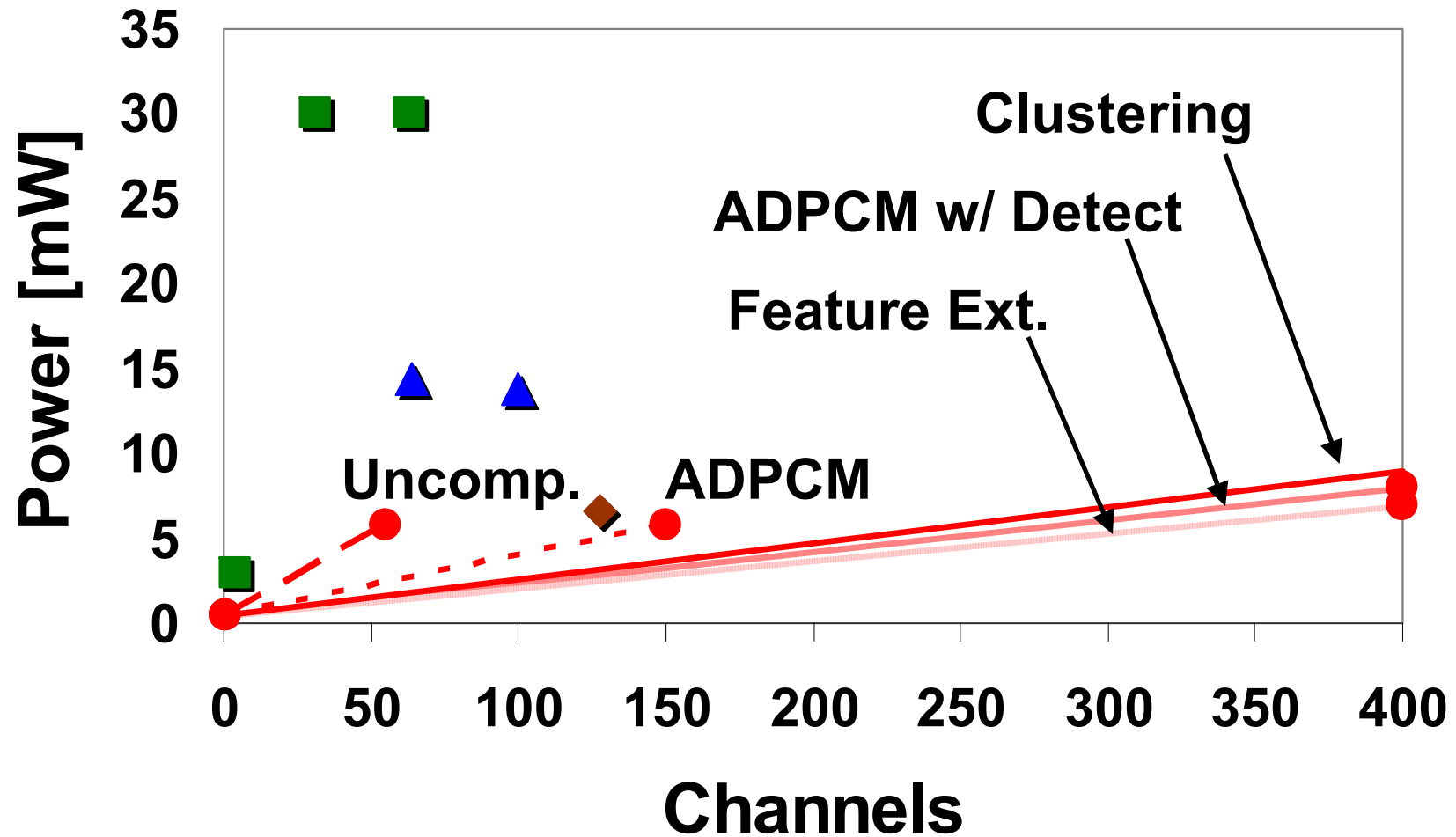

- Our approach provides:
 - lower power and greater flexibility

Outline

- Motivation
- Existing System Implementations
- Proposed System Architecture
- Performance Comparison
- **Conclusions**

Conclusions

- **Experimental need for low-power circuits for neural-signal amplification, processing, and telemetry**
- **Proposed Amplifier Design**
 - **Low-voltage cascaded differential amplifiers:**
 - **Better than state-of-the-art circuits by a factor of $\geq 2.5x$**
- **System-Optimization Study**
 - **Analog vs. Digital ADC and Spike Detection**
- **Overall System Performance**
 - **Less Power, More Channels, Greater Flexibility**

Acknowledgements

- **Faculty Collaborators:**
 - EE: Profs. Judy, Marković, Razavi, Parmarti
 - Neuro: Blair
- **Students and Postdocs:**
 - Shahin Farshchi
 - Sarah Gibson
 - Vaibhav Karkare
- **Members of Judylab at UCLA**
- **NSF Grants: DBI-0456125 and EECS-0824275**

Questions?

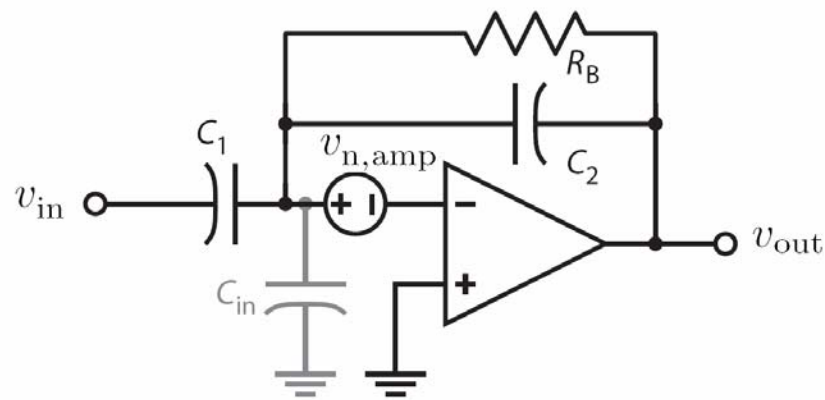
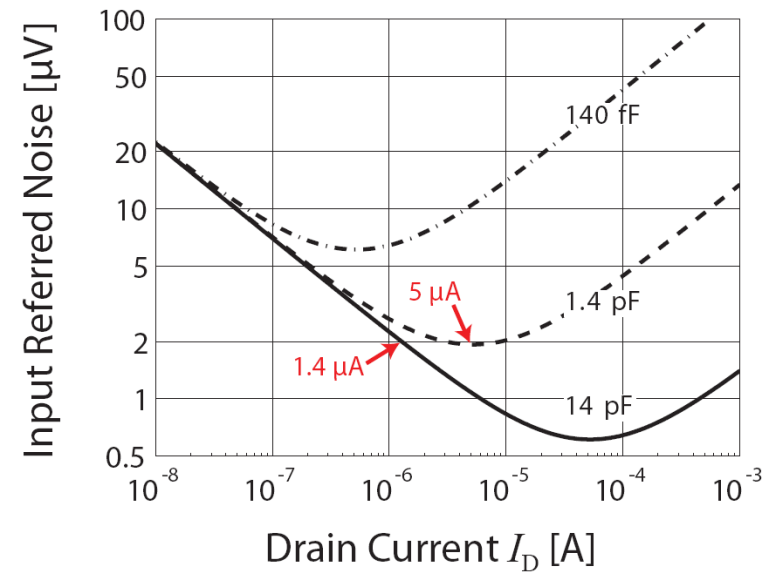
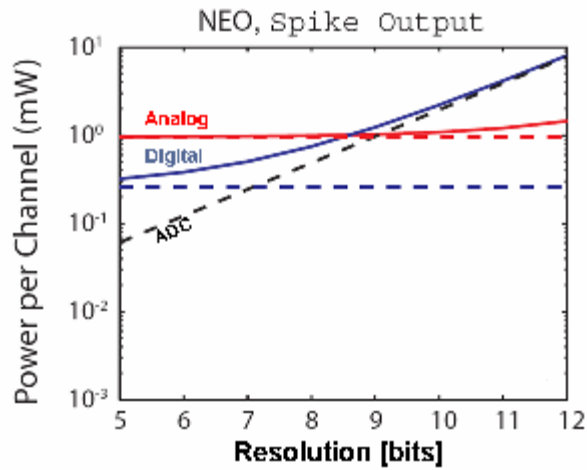

Backup: Noise Contributions

