

Homework #4

Due Mon., Oct. 31, 2011

1. Problems 6.6, 6.8 (b), (e), 6.12.
2. Problems 7.5, 7.6 (c), (f)
3. Problem 7.9 (e), (f).
4. In this problem, use the Cadence or HSPICE device models for both hand calculations and simulations. In parts (a) and (b), neglect channel-length modulation and body effect. Assume the tail current source requires a minimum voltage of 0.20 V to remain in saturation. Assume $I_{SS} = 250 \mu\text{A}$, $V_{DD} = 1.8 \text{ V}$, $C_L = 0.5 \text{ pF}$, $(W/L)_{4-6} = 40/0.18$, and M_1 - M_3 also have a channel length of 0.18 μm .

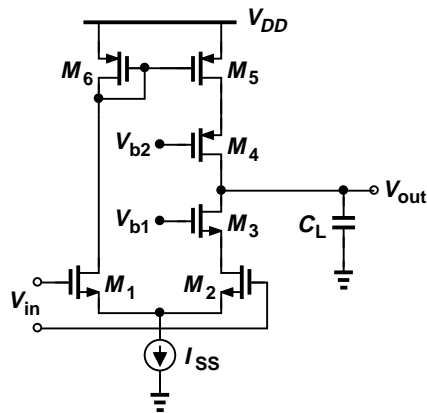

- (a) Determine the widths of M_1 - M_3 such that their overdrive voltage is equal to 0.18 V.
- (b) With an input CM level of 0.7 V, find the minimum value of V_{b1} and maximum value of V_{b2} for which M_2 and M_5 remain saturated (if M_3 and M_4 are saturated.) What is the maximum output voltage swing?
- (c) Estimate the magnitude of the mirror pole.
- (d) Estimate the small-signal gain and unity-gain bandwidth of the circuit and verify your results by simulation. (For simulation results, turn in only a hardcopy of the netlist or schematic and just quote the measured numbers. To save the earth, avoid printing Cadence diagrams with a black background.)