

Single-Stage Amplifiers

Many aspects of the performance of amplifiers are critical. We summarize the trade-offs as shown below.

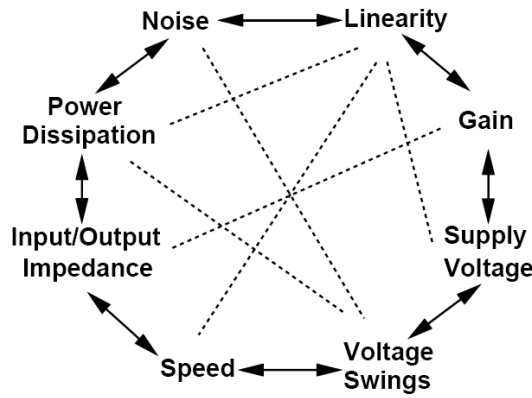

The amplifiers to be studied here include: CS and CG stages, source followers, and cascades. For each stage, we wish to study both the large-signal and small-signal properties.

Common Source Stage

- Large-Signal Behavior

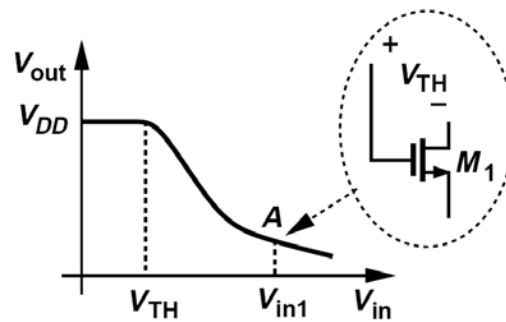
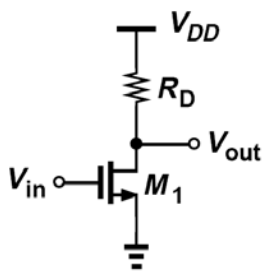

What is the small-signal gain in this region?

At point A:
$$V_{in1} - V_{TH} = V_{DD} - R_D \frac{1}{2} \mu_n C_{ox} \frac{W}{L} (V_{in1} - V_{TH})^2$$

How do we maximize the gain?

- Small-Signal Analysis

We assume that the bias currents and voltages are chosen such that M_1 is in saturation and Q_1 in forward active region.

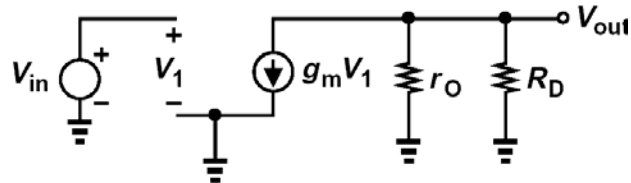

Voltage Gain:

Many CMOS technologies do not have resistors with useful sheet resistivity. So we try other tricks:

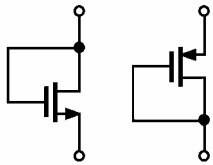

This device can operate as a resistor. How about this:

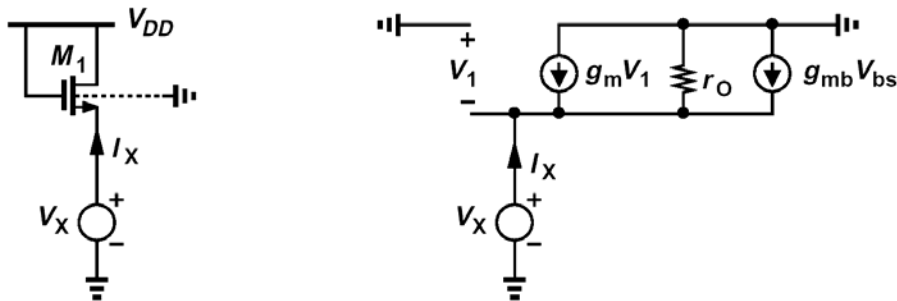

Common Source with “Diode” Load

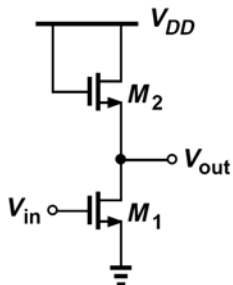

How do we maximize the voltage gain here?

Large Signal Behavior:

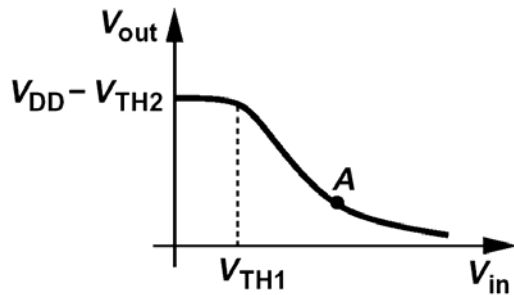

Example: Common Source with PMOS Diode Load

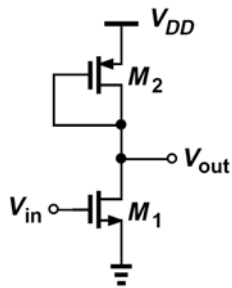

Both versions suffer from serious headroom limitations at low supply voltages.

CS Stage with Current Source Load

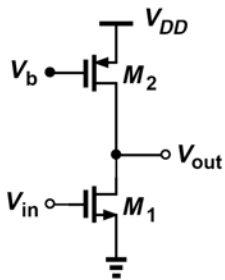

What happens to the gain as I_D decreases?

CS Stage with Triode Load

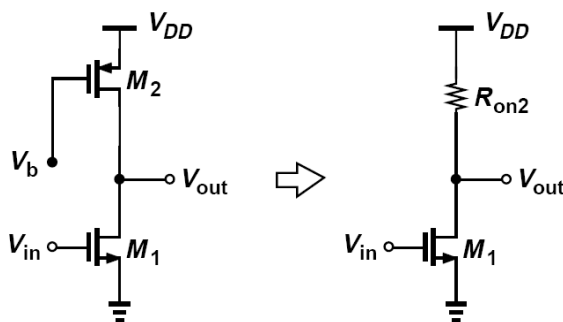

CS Stage with Source Degeneration

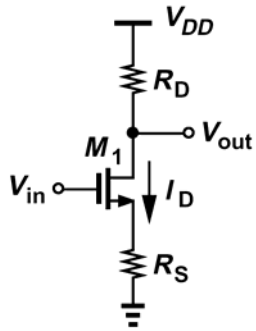

It is useful to find the Gm of the stage:

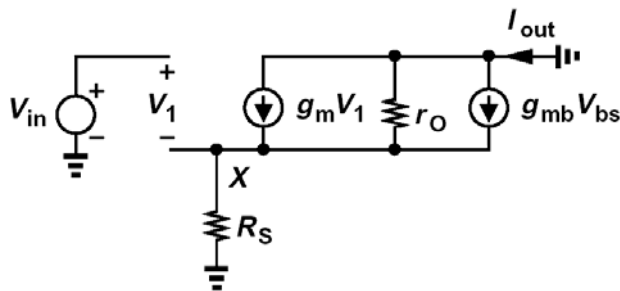

Also, the output impedance:

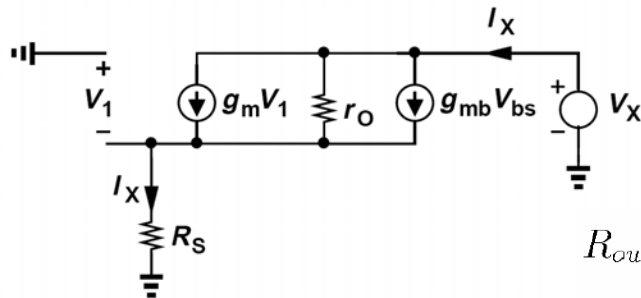

$$R_{out} = [1 + (g_m + g_{mb})R_S]r_O + R_S$$

$$= [1 + (g_m + g_{mb})r_O]R_S + r_O.$$

From another perspective:

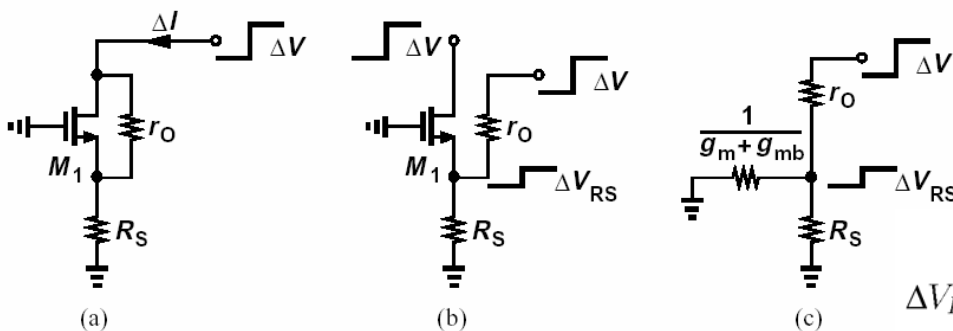

$$\Delta V_{RS} = \Delta V \frac{\frac{1}{g_m + g_{mb}} || R_S}{\frac{1}{g_m + g_{mb}} || R_S + r_O}$$

Now let's compute the gain by noting that:

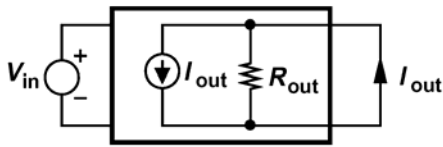

$$\frac{V_{out}}{V_{in}} = \frac{-g_m r_O R_D}{R_D + R_S + r_O + (g_m + g_{mb}) R_S r_O}$$

If $\lambda=0$ and $g_{mb}=0$, then:

Example

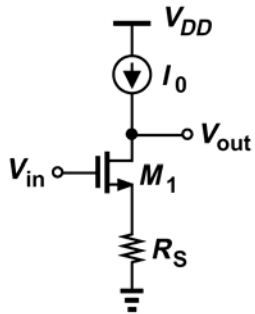

Source Followers

- Large-Signal Behavior

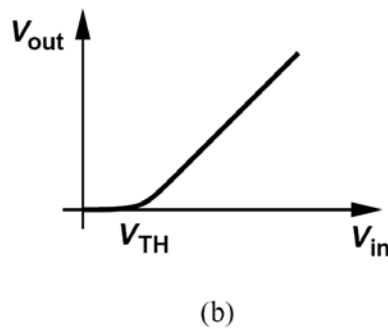
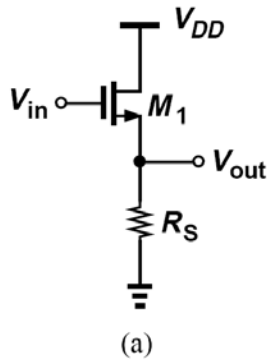

Sketch the gain vs. input.

- Small-Signal Behavior

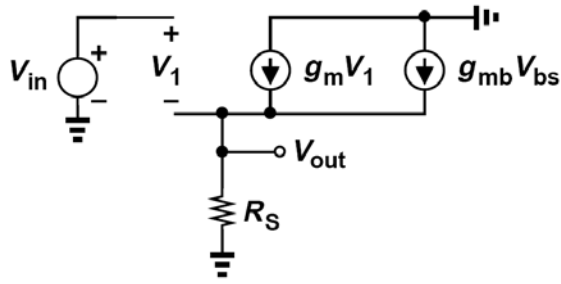

$$A_v = \frac{g_m R_S}{1 + (g_m + g_{mb}) R_S}$$

- Often use a current source in place of R_E and R_S to have a better definition of the bias current.

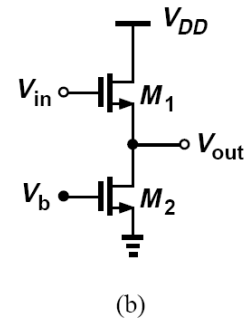
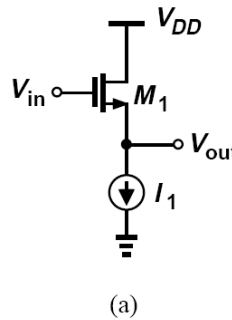

How good a buffer is a source follower? Input impedance =

Output Impedance:

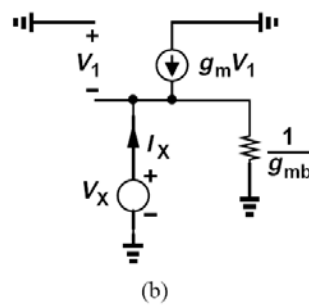
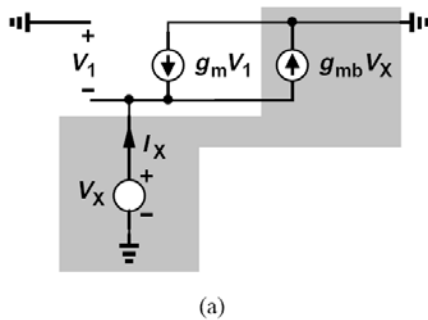

Another method of finding the gain:

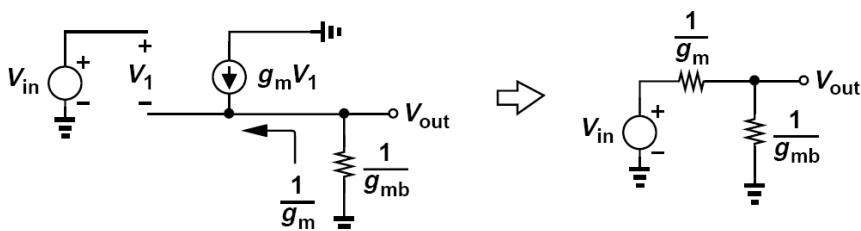

- Can eliminate body effect in PMOS version:

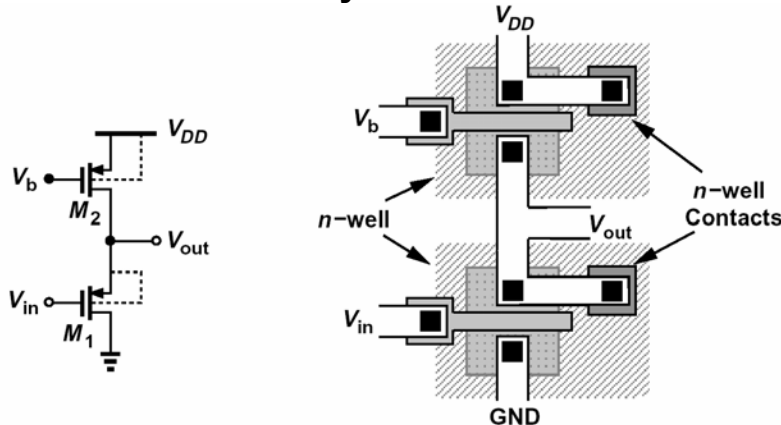

- Source followers are used only occasionally. They introduce noise and consume voltage headroom. For example:

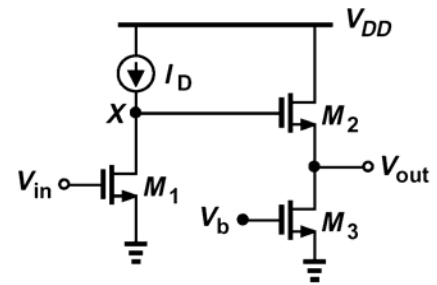

Common-Gate/Base Stage

- Large-Signal Behavior

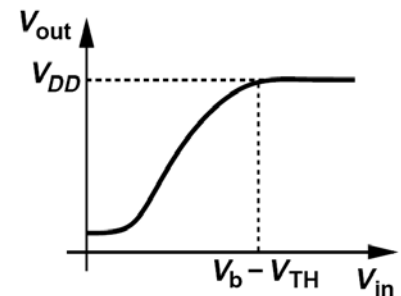
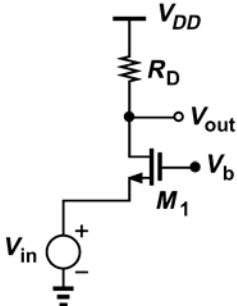

- Small-Signal Behavior

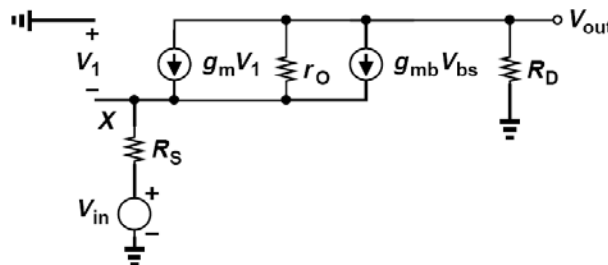
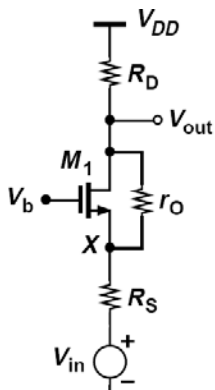

$$\frac{V_{out}}{V_{in}} = \frac{(g_m + g_{mb})r_O + 1}{r_O + (g_m + g_{mb})r_O R_S + R_S + R_D} R_D$$

• Input Impedance

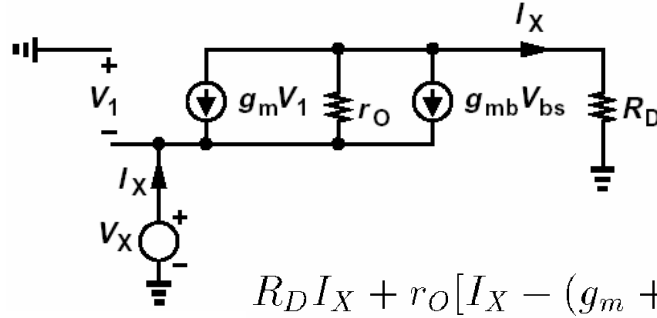
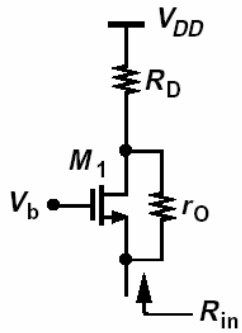

$$R_D I_X + r_O [I_X - (g_m + g_{mb}) V_X] = V_X.$$

$$\frac{V_X}{I_X} = \frac{R_D + r_O}{1 + (g_m + g_{mb}) r_O}$$

$$\approx \frac{R_D}{(g_m + g_{mb}) r_O} + \frac{1}{g_m + g_{mb}}$$

Example

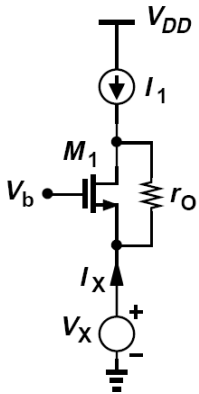

• Output Impedance

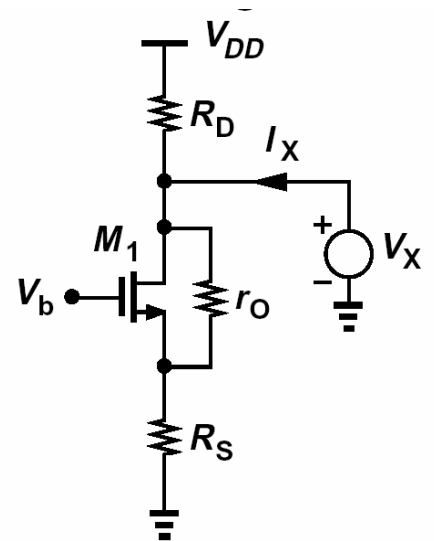

Cascode Stage

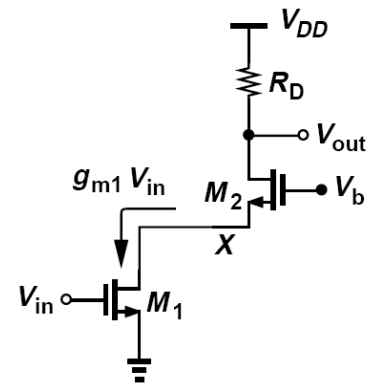

How do we choose the bias conditions?

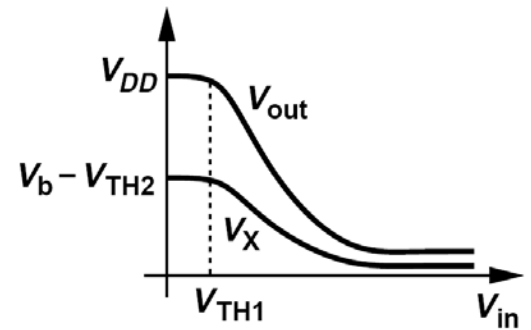
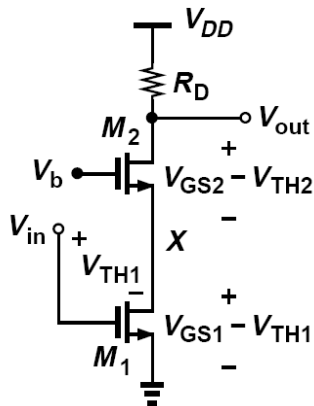

What is the maximum output voltage swing?

Gain Calculation:

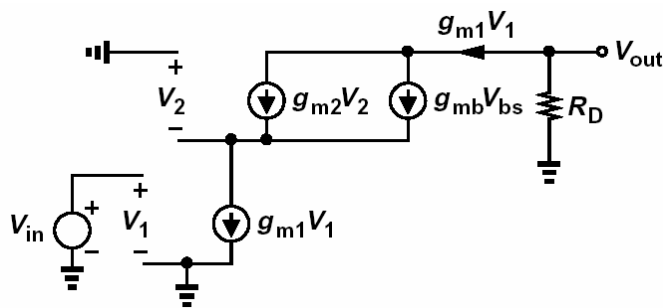

Output Impedance:

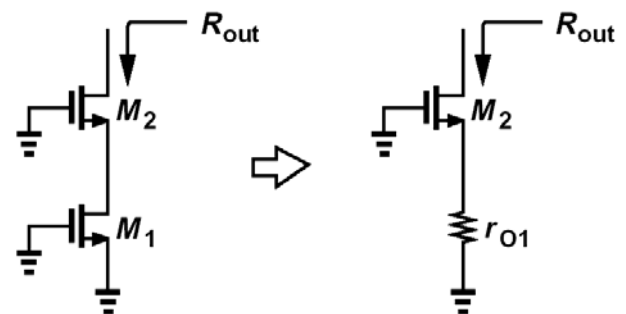

Cascode Stage with Current Source Load

Bias currents and voltages are chosen such that all MOSFETs are in saturation.

Voltage Gain:

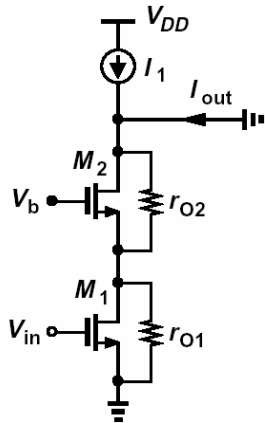

$$I_{out} = g_{m1} V_{in} \frac{r_{O1}}{r_{O1} + \frac{1}{g_{m2} + g_{mb2}} || r_{O2}}$$

$$G_m = \frac{g_{m1} r_{O1} [r_{O2} (g_{m2} + g_{mb2}) + 1]}{r_{O1} r_{O2} (g_{m2} + g_{mb2}) + r_{O1} + r_{O2}}$$

$$|A_v| = G_m R_{out} = g_{m1} r_{O1} [(g_{m2} + g_{mb2}) r_{O2} + 1]$$

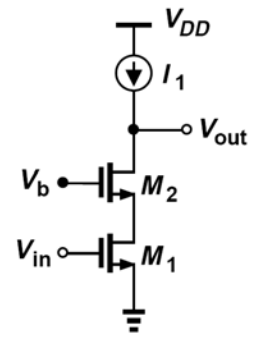

How do we maximize the voltage gain?

Actual realization:

Gain calculation:

$$R_{out} = \{ [1 + (g_{m2} + g_{mb2}) r_{O2}] r_{O1} + r_{O2} \} || \{ [1 + (g_{m3} + g_{mb3}) r_{O3}] r_{O4} + r_{O3} \}$$

$$A_v \approx g_{m1} [(g_{m2} r_{O2} r_{O1}) || (g_{m3} r_{O3} r_{O4})]$$

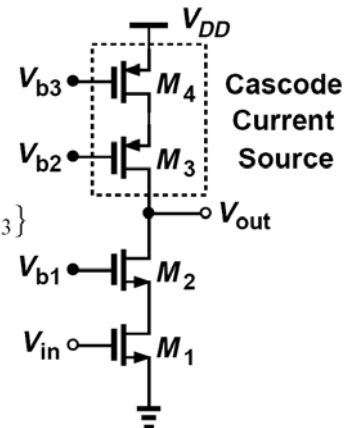

Folded Cascode

The input and cascode devices need not be of the same type.

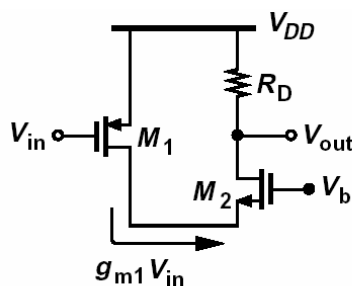

(a)

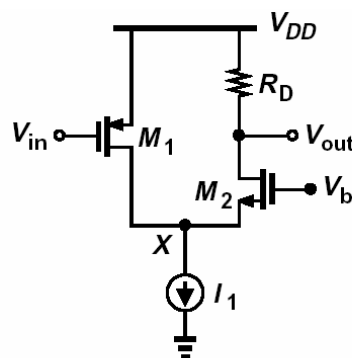

(b)

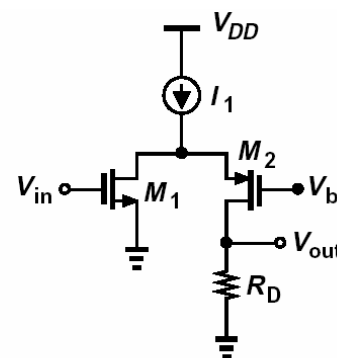

(c)

What is the application?

- Large-Signal Behavior

Let the input decrease from V_{DD} to zero.

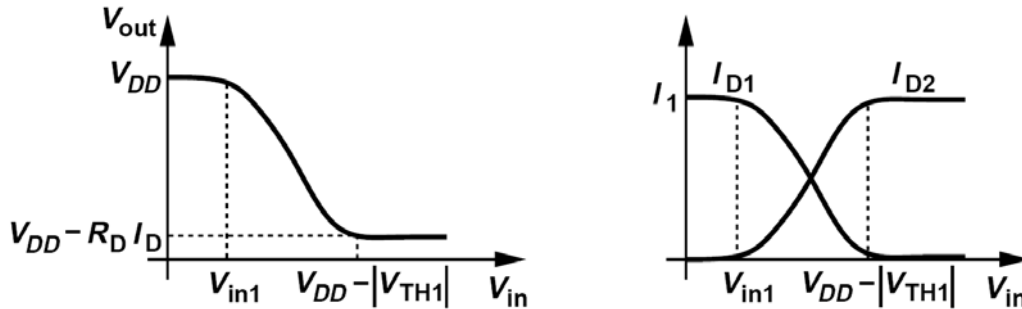

$$V_{in1} = V_{DD} - \sqrt{\frac{2I_1}{\mu_p C_{ox} (W/L)_2}} - |V_{TH1}|$$

- Small-Signal Behavior

Similar to that of simple cascode.

Example

