

## Homework #2

Due Wed., Jan. 20, 2010

1. (a) Neglecting device capacitances, calculate the noise figure of each circuit with respect to a source resistance  $R_S$ . Assume devices operate in saturation and  $\lambda = \gamma = 0$ . What happens to the noise figure if  $R_D \rightarrow \infty$ ? Can you explain these results intuitively?
- (b) Now suppose  $g_{m2} \rightarrow 0$  while  $R_D \neq \infty$ . What happens to the noise figure?

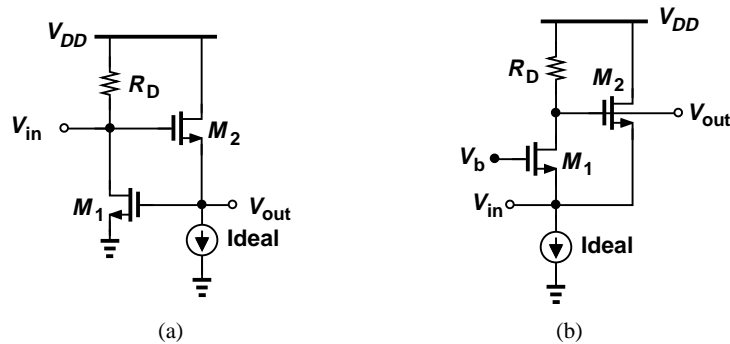

2. In this problem, we use HSPICE or Cadence to study the noise behavior of a two-stage amplifier similar to that introduced in Homework #1:

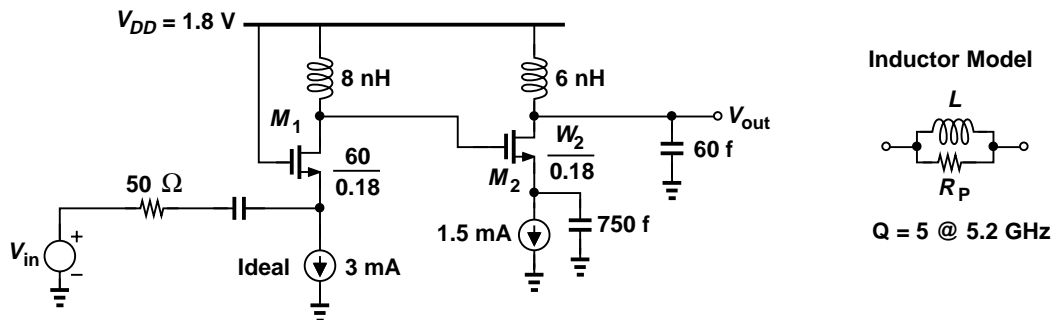

- (a) Choose the width of  $M_2$  to create resonance at 5.2 GHz at the drain of  $M_1$ . Note that the two stages interact through Miller multiplication of  $C_{GD2}$ .
- (b) Find the transistor transconductances and output resistances from SPICE or Cadence and calculate the noise figure of the first stage by hand. Compare the result with that obtained by simulation. (The first stage is always loaded by the second stage.)
- (c) Using SPICE or Cadence, find the noise figure of the overall amplifier. What is the contribution of the second stage to the NF (i.e., the NF with and without the second stage)? (The first stage is always loaded by the second stage!)