

# Use of D.C. Relays in Home Audio Systems

FRANCIS F. CHEN\*

D.c. relays can have several advantages in audio systems because they do not produce hum nor do they chatter. They are especially valuable in control applications such as the automatic turntable shutoff, remote control, and clock-timer described in this article.

IT IS WELL KNOWN that sensitive d.c. relays which operate on only a few milliamps of current have several advantages over the usual a.c. relays which are energized by either the 117-volt line or the 6 volts of a.c. in the filament circuit. One of these advantages is particularly important to audio systems: d.c. does not produce hum. A second advantage is that d.c. relays do not chatter upon closing, since the exciting voltage does not go to zero and reverse, as it does in a.c.

In this article three illustrations are given in which the audiophile can make use of these properties of d.c. relays in the power switching of his home audio system. In the first example, a simple circuit is described which will automatically turn off a turntable at the end of a record without any interaction with the tonearm during the play of the record. The second example is a versatile relay circuit with which remote, automatic switching of the power to the entire audio system can be performed. In the third example, it is shown how an

\* P. O. Box 31, Kingston, N. J.

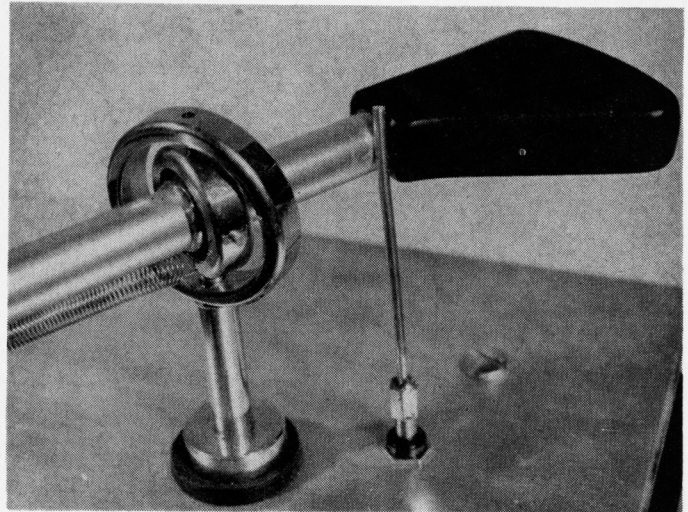
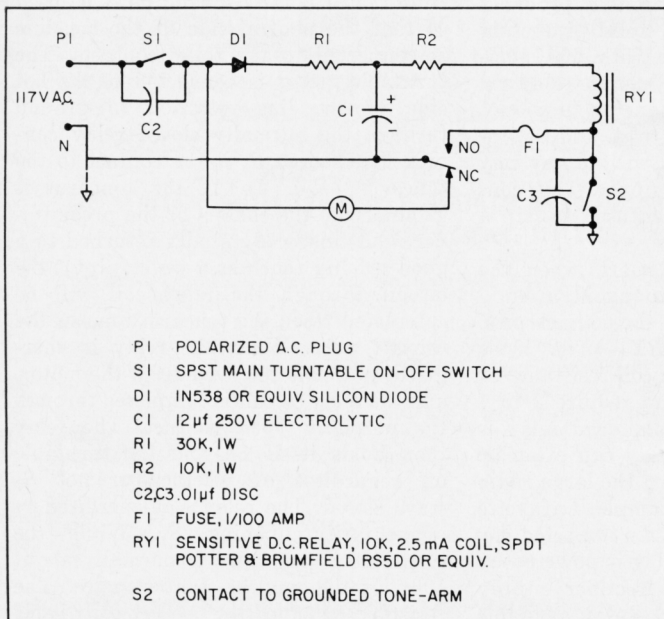

Fig. 2. Close-up view of contact for shutting off turntable automatically at end of record. CAUTION: Do not use bare wire as shown here; wire should be either of the enamelled variety or covered with spaghetti and bared only in the contact area.

accurate timer can be made, which can switch on a tape recorder or an entire stereo system within a fraction of a minute of a predetermined time. These are of course, only illustrations of ways in which relays can be used; but from these examples the audio hobbyist should be able to design circuits suitable for his own particular needs.

## I. AUTOMATIC TURNTABLE SHUT-OFF

Much of the inconvenience of a turntable, as contrasted to a changer, can be avoided merely by making a device to turn the player off at the end of a record, thus eliminating the annoying click-clack of the runout groove and allowing the listener to change the record at his leisure. At least two such devices are available commercially, but one of them is quite costly, and the other is a purely mechanical device which lifts off the tonearm but does not provide any electrical signal for switching off other components. The relay circuit shown in Fig. 1 is simple, reliable, inexpensive, and can be used with any metallic tonearm.

The two most important requirements of a switch-off device are that it should not interfere in any way with the delicate balance of the tonearm and that it should not introduce any hum. One way to detect that the record has ended is to make use of the absence of audio signal or the approximately 1-cps clicking signal from the runout groove. This method would have no interaction, either electrical or mechanical, with the tonearm at all. However, a little thought shows that such a device would be very difficult to perfect and adjust. One could also use

Fig. 1. Schematic of automatic turntable shutoff.

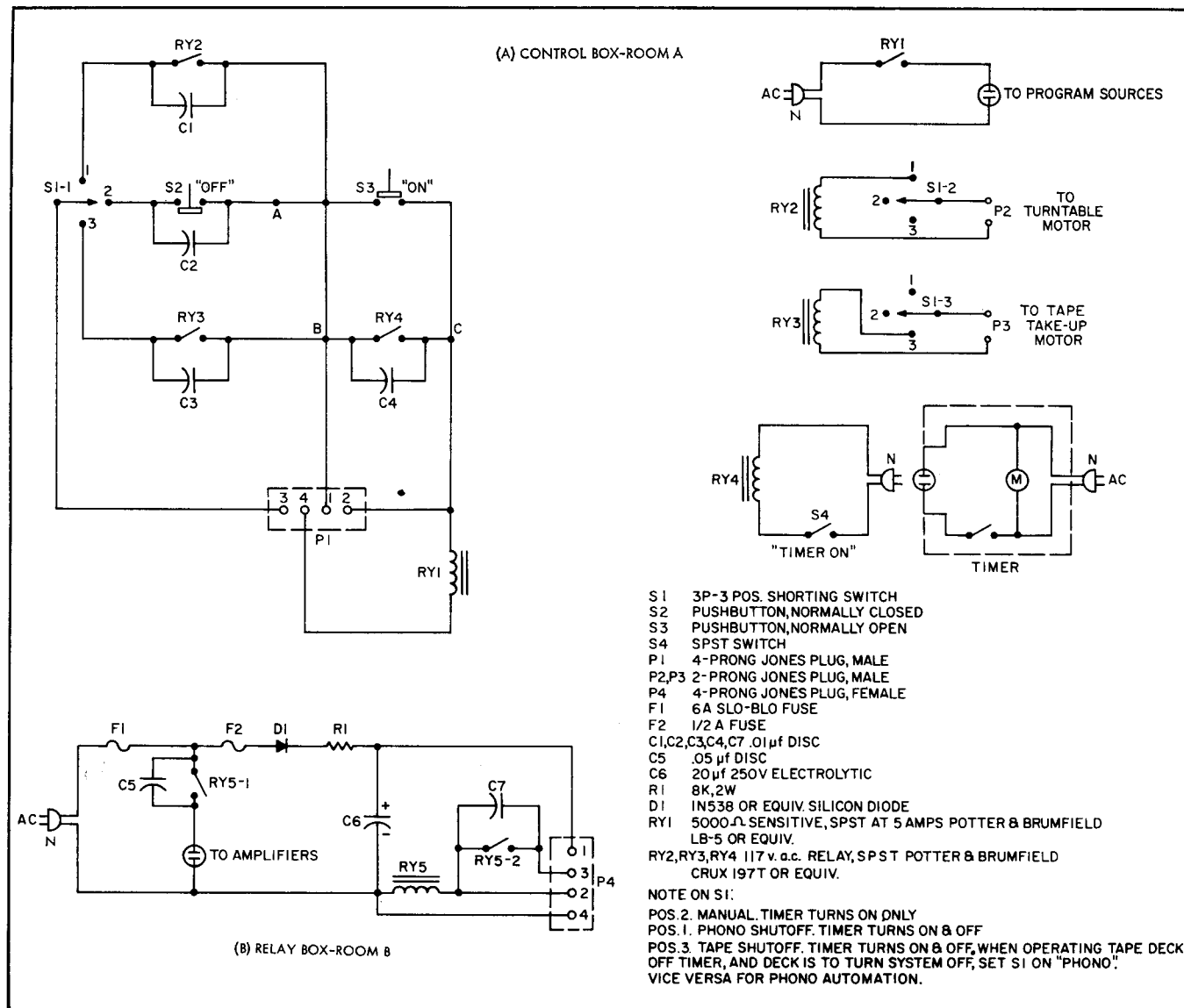

Fig. 3. Schematics of control and relay boxes.

a photocell to rig up an "electric eye" device to tell from its shadow when the tonearm has reached the inner radius of the record. This method also has no direct interaction with the tonearm, and the circuit could be fairly simple. This was tried, but it turned out that it was hard to adjust the sensitivity so that it would work under all conditions of ambient light, unless a complicated, collimated light source was built. Thus we decided to use a direct electrical contact on our metallic tonearm.

As shown in Fig. 2, this involves only a small, inconspicuous addition to the turntable. A small hole is drilled in the baseboard in the region of the tonearm overhang, and a feed-thru insulator is mounted in the hole. A fairly stiff bare<sup>1</sup> wire (about #14 AWG) is soldered to the feed-thru and bent so that it makes contact with the rear part of the tone-

arm when the latter enters the runout groove. This adjustment is quite easy to make. To ensure that an electrical contact is made with the arm, it is probably necessary to rub off the finish-protecting coating on the tonearm with fine sandpaper or emery cloth. Since the tonearm itself is used as a conductor, it is not necessary to add wires to it, and its operation is not interfered with in any way until after the record is over. This contact,  $S_2$  in Fig. 1, is then used to trip a relay.

To prevent a large spark when the contact is made and to avoid a hum-inducing a.c. voltage on the contact wire, a sensitive d.c. relay  $RY_1$  (Fig. 1) is used. This should have a coil resistance of 5000 to 10,000 ohms and require 2 to 4 ma of coil current. A standard relay is listed, but a suitable relay can often be obtained at less cost from the large radio supply houses. (For example, Lafayette Radio in New York sells an imported d.c. relay for \$1.95.) The relay is powered by d.c. from a half-wave rectifier supply consisting of diode  $D_1$  (also available

cheaply from the large supply houses) and the filter  $R_1$  plus  $C_1$ . The switch  $S_1$  is the on-off switch for the turntable. Note that a polarized plug must be used so that the neutral side of the a.c. line is connected to the relay contacts. The turntable motor is connected to the hot side of the line returned to ground through the normally closed relay contact. The switch  $S_2$  is the contact to the tonearm (Fig. 2). If the tonearm is grounded to the chassis of the preamplifier, and this is eventually returned to a good ground (such as a water pipe), the circuit through the relay coil will be completed when the tonearm touches the contact wire. When the relay is energized, power is removed from the motor, and the relay circuit is completed through the normally open contact. The relay then holds itself on and the turntable off regardless of whether or not  $S_2$  stays closed. The relay is de-energized by momentarily opening  $S_1$ . While the turntable is on, there is normally about 100v of d.c. on the contact wire. The resistor  $R_2$  and the relay coil itself

<sup>1</sup> In order to reduce the danger of shock, we recommend that this wire be insulated by means of spaghetti or that it be enamelled wire and that it be bared *only* in the contact area. Ed.

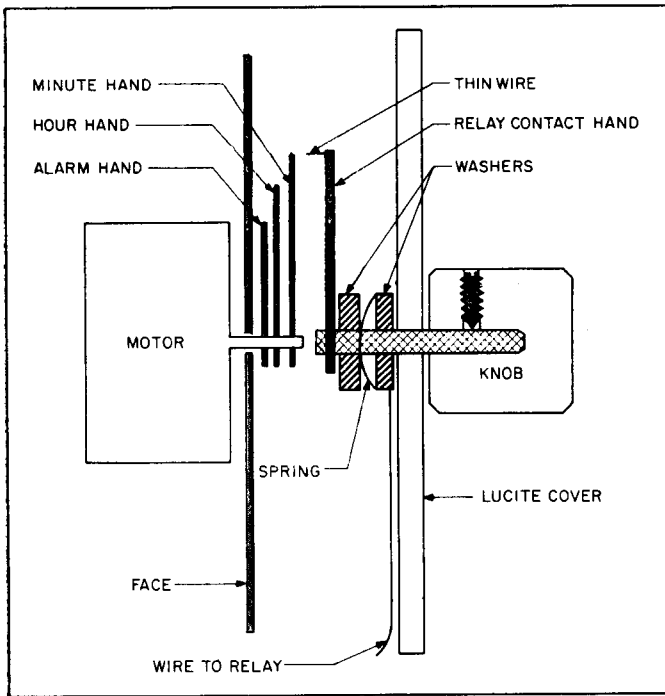

Fig. 4. Selection of clock front area showing placement of relay contact hand wire to relay.

limit the current to about 5 ma in case the wire is touched accidentally; this cannot be felt. In the unlikely circumstance that  $P_1$  is accidentally reversed (if a polarized plug is not used), and the relay closes, and the contact wire is touched, one could conceivably get a shock from the power line (see note 1). The fuse  $F_1$  protects the user against this contingency. The capacitors  $C_2$  and  $C_3$  are the usual switch bypasses to eliminate "pops."

This circuit has worked admirably without failure for several months on a Weathers turntable with a Dynaco B & O arm. Since no power transformer is used, there is no noticeable hum due to this circuit, and no clicks or pops when the turntable goes off. Current has to flow through the tonearm only for a few milliseconds while the relay closes; after this the holding-contract arrangement supplies current to the relay. Note that the contact to the tonearm need not be very good—the high impedance of the

relay power supply makes it a constant-current source which will trip the relay even though the contact has thousands of ohms of resistance. There is only one word of warning: with turntables with idler wheels, be sure to release the idler within a reasonable time to prevent flat spots from developing.

## II. AUTOMATIC POWER CONTROLS

The circuits shown in (A) and (B) of Fig. 3 are designed to allow remote control of the power amplifiers (in Room B) from the equipment cabinet (in Room A). The location of the power amplifiers outside the living room is really the sensible thing to do, since these amplifiers are generally unsightly and space-consuming, and moreover generate heat and hum. They can, of course, be turned on and off from the preamp if a power cord is strung between the two rooms. However, the Fire Underwriters' Code requires that such a wire, going

through a wall, must be AWG #14 or larger; and this gives rise to some problems in installation and decor. On the other hand, the small amount of power required to trip a control relay can be handled by a small, inconspicuous wire. If this were the only reason, the use of relays would hardly be justified; but as we shall see, the use of a holding relay allows us to incorporate a number of automatic features.

The d.c. relays in this case are  $RY_5$  in Room B, (B) of Fig. 3, which supplies power to the amplifiers, and  $RY_1$  in Room A, (A) of Fig. 3, which controls the program sources. The reason d.c. relays should be used here is that they will not chatter upon closing. When a.c. relays were tried, they occasionally caused the fuse to blow on the amplifiers because of large current surges induced when the contacts bounced upon closing. The power to activate these relays comes from a half-wave rectifier consisting of diode  $D_1$ , capacitor  $C_0$ , and the current-limiting resistor  $R_1$ . One contact of  $RY_5$  is used to switch the amplifiers. The other contact is hooked up in a holding arrangement so that once the relay is tripped (by shorting pins 1 and 2 on Plug  $P_1$ ), it is held in the energized condition by current which comes from pin 3 of  $P_1$  through the second pole of  $RY_5$ . Power is turned off when the d.c. on pin 3 is removed momentarily. These operations are performed in the control box, which is connected to  $P_1$  by a small four-conductor cable.

To turn the system on, the normally open pushbutton,  $S_2$ , is pushed, momentarily shorting pins 1 and 2 of  $P_1$  (or  $P_1$ ). This trips  $RY_5$ , as previously described; and both relays,  $RY_1$  and  $RY_5$ , are then held closed by current which flows from pin 1 of  $P_1$  through the normally closed "off" button  $S_1$  and selector switch  $S_{1-1}$  (shown in the "manual" position) and through pin 3 and the contact  $RY_{5-2}$  to the relay coils. This circuit is broken momentarily by pushing the "off" button, and this is sufficient to de-energize  $RY_5$  and  $RY_1$ , turning off the power to the entire system.

With this arrangement, it is now easy to add the automatic features. To turn the system off automatically at the end of a record, the "off" button is replaced by the contact of  $RY_2$  by turning the switch  $S_1$  to the No. 1, or "phono," position. At the same time,  $RY_2$  is energized by the second pole of  $S_1$ . The coil of  $RY_2$  is connected in parallel with the motor of an automatic turntable or charger, which is already on. When this is turned off, for instance by the circuit of Fig. 1,  $RY_2$  is de-energized, and power is removed from pin 3 of  $P_1$ , turning off the entire system. The same function can be performed by a tape recorder by  $RY_2$ , and the No. 3, or "tape," position of  $S_1$ . The coil of  $RY_1$  is connected to the take-up motor of the recorder, and

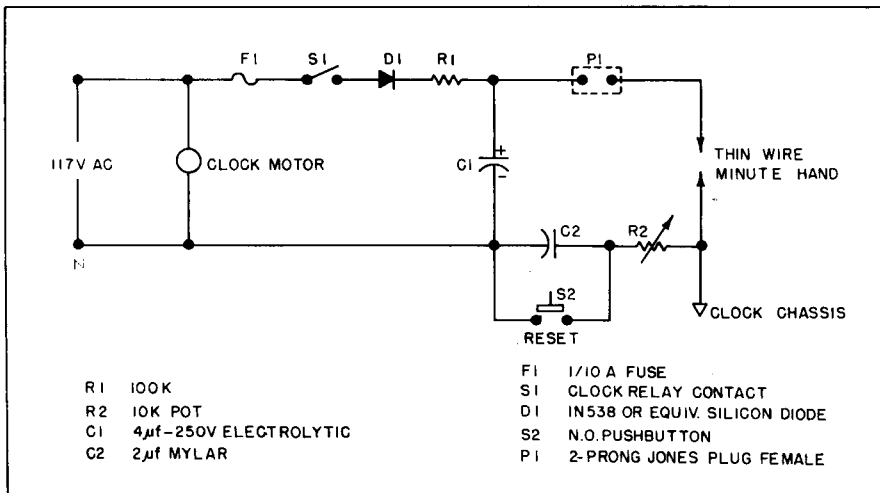

Fig. 5. Schematic of clock-timer.

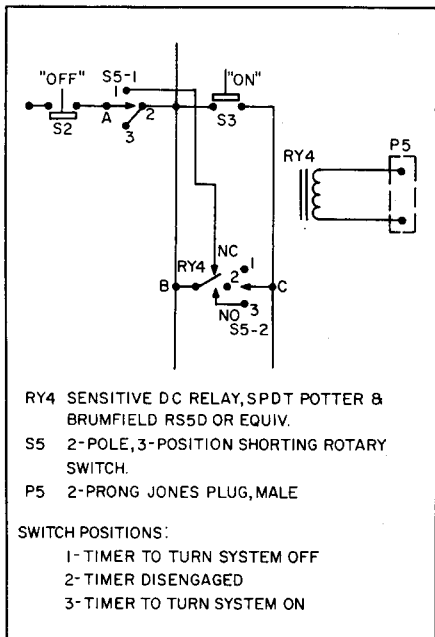

Fig. 6. Modification of control box for clock-timer.

when this is turned off automatically at the end of a tape, the entire system is turned off.

For automatic turning on of the system at a preset time, the contact of relay  $RY_4$  is used in parallel with the manual "on" button. The coil of  $RY_4$  is plugged into an ordinary appliance timer, which energizes it at a preset time only if the timer switch  $S_4$  is closed. This will allow a radio program to be recorded automatically in one's absence, or will turn on a record or tape automatically, say, during a party at which the host is busy with other chores. If  $S_1$  is in the "manual" position, the system will stay on. If it is in the "tape" or "phono" position when the corresponding device is used, the system will turn off when the tape or record ends or when the timer turns  $RY_4$  off, whichever occurs later. If the switch  $S_1$  is in the "tape" position when a turntable or tuner is used, or in the "phono" position when a recorder or tuner is used, the timer alone will determine the turn-off time. This is useful, for instance, when one wants to retire at a given time. Almost any type of relay can be used for  $RY_2$ ,  $RY_3$ , and  $RY_4$ , and for simplicity we have chosen relays that operate off

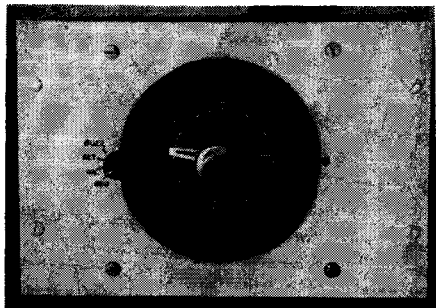

Fig. 7. Front view of clock-timer. Note extra hand.

the line voltage so that no special power supply has to be built. There is a danger that hum from the relay coils will be picked up in the preamp; however, this has not been noticeable.

This switching system has been operating without failure for a year and a half. Its main contribution has been to free the listener from being tied down by FM schedules. With automatic tape recording, one can listen to FM concerts at his leisure regardless of when the broadcast actually occurred.

### III. AN ACCURATE CLOCK-TIMER

Anyone who has tried to tape a program while he was away has probably come across this problem: ordinary appliance timers cannot be set very accurately, and coming within five minutes of the desired time would be considered above par. This means that you either miss the first few minutes of a symphony, or you have 200 feet of wasted tape at the beginning of a reel—and perhaps not enough at the other end to finish the recording.

This problem can be licked by adding essentially the relay circuit of Fig. 1 to an ordinary appliance timer. Such a timer can be obtained for about \$3 from the large electronics supply houses (for instance, Radio Shack in Boston) and is simply an unmounted electric clock movement with an alarm hand which can be set to turn on a SPST switch. The clock is mounted on a piece of lucite (plexiglas), which in turn is screwed onto an aluminum utility box which houses both the clock and the electronics.

A fourth hand (in addition to the clock's hour, minute, and alarm hands) is now attached to the lucite face, as shown in Fig. 4. This consists of a knob, a piece of  $\frac{1}{4}$ -in. potentiometer shaft, a stiff piece of wire to form the hand, and a small piece of fine flexible wire soldered to the hand. The fine wire is placed at such a radius that it makes electrical contact with the minute hand but not with the hour hand. This fourth hand is wired electrically by means of a fine wire soldered to a washer which makes contact with the shaft as the hand is rotated.

Here is how it works. In Fig. 5,  $D_1$ ,  $R_1$ , and  $C_1$  will be recognized as the d.c. power supply for a sensitive relay, whose coil is connected across plug  $P_1$ . The alarm hand is set about 15 minutes before the desired time, so that nothing happens until the proper hour arrives. When the built-in alarm of the clock goes off, the switch  $S_1$  closes, and our d.c. power supply is energized. A d.c. voltage appears on the fine wire of the fourth hand, but no current can flow until this hand makes contact with the minute hand, which is grounded to the chassis. Imagine, for the moment, that the capacitor  $C_2$  is replaced by a short. Then when the thin wire makes contact,

the circuit is completed, and the d.c. relay is energized to turn on the power to the audio system. Since it is possible to set the fine wire to a given position quite accurately, the relay can be made to trip within a fraction of a minute of the desired time.

Note that the line plug should be polarized as shown so that no voltage appears on the clock mechanism. For added safety, the clock mechanism should be insulated from the metal case; this is easy to do since the clock is mounted on an insulating lucite panel. Note also that the fine wire of the fourth hand should be flexible enough to allow the minute hand to brush by an indefinite number of times.

The trouble with this circuit is that most clock mechanisms turn switch  $S_1$  on but not off;  $S_1$  must be reopened manually. This means that the relay will trip once every hour until you return to reset  $S_1$  manually. This defect is overcome by adding the capacitor  $C_2$  and the reset button  $S_2$ . Now current can flow through the relay coil only for a few milliseconds until  $C_2$  is charged up. The potentiometer  $R_2$  is adjusted so that a current pulse just large enough to trip the relay is passed when the thin wire contact is made. When the contact is broken, as the minute hand moves past,  $C_2$  will be left charged. An hour later, when the contact is again made, no current can flow since  $C_2$  (and the minute hand) are still charged. For this purpose, it is obvious that the clock must be well insulated. The capacitor  $C_2$  must also hold its charge for an hour. It was found that mylar capacitors are good enough for this purpose. The voltage drop after an hour is so small that on successive contacts with the minute hand too small a current flows through the relay to trip it. At the same time, each contact charges  $C_2$  back to full voltage for the next hour. This cycle then repeats until you return to reopen  $S_1$  manually. The reset button  $S_2$  should be pushed when setting the timer to make sure that  $C_2$  is discharged.

This timer is incorporated into the relay circuit (A) of Fig. 3 by adding the circuit of Fig. 6 at the points labeled A, B, and C. The relay  $RY_4$  in (A) of Fig. 3 is now replaced by a sensitive d.c. relay with SPDT contact. The plug  $P_5$  is connected to  $P_1$  (Fig. 5) by a twin lead. The switch  $S_5$  enables one to disable the timer, or make it turn the system on or off (but not both) at a given time. This timer can, of course, be used without the entire circuit (A) of Fig. 3. In this case  $RY_4$  should have DPDT contacts, and one pole should be hooked up as a holding contact, while the other is used to switch power to the system.

The face of the clock-timer is shown in Fig. 7. This circuit has worked well for several months and has proved to be a great boon to tape recording. Æ